

10.2 LARGE HOLES AND CUTOUTS

Some designs may occur in which it is necessary or desirable to have relatively large holes or cutouts in a plate, such as lightening holes in the web of a beam or cutouts in a plate structure. A limited amount of data is available for problems of this type; however, available solutions will be discussed in this section.

10.2.1 Bending of Plates with Circular Holes

Solutions have been obtained in Ref. 18 for a uniformly loaded square plate either simply supported or clamped along the outer boundary with a central circular hole as shown in Fig. B10-28. Results for deflections and bending moments for each boundary condition are given in Tables B10-2 and -3.

10.2.2 Holes in Beam Webs

Holes are frequently cut in the webs of beams to provide for passage of pipes and ducts, for access to the inside of a box beam, or for weight saving. Little information is available on the stress distribution around holes in beam webs.

An analytical method for calculating stresses around holes in the web of wide flange beams shown in Fig. B10-29 is presented in Ref. 19. The applicability of the analysis depends on the size of the hole and on the magnitude of the moment-shear ratio at the hole. The analysis is primarily applicable to circular holes; as for elliptic holes, limits of applicability of the analysis technique were not established.

Section B10
15 May 1972
Page 16

An empirical technique for the analysis of webs with round lightening holes having formed 45 deg flanges is presented in Ref. 20.

Table B10-1. Stress Concentration in a Plate Due to Uniformly Spaced Circular Holes

$$\frac{p}{p} = 0.92$$

<div style="text-align: center;">Configuration</div> <div style="text-align: left; padding-top: 10px;">Biaxial loads</div>				
$\sigma_1 \neq 0, \sigma_2 = 0$ Uniaxial Tension	12.5	19.4	23.0	37.0
$\sigma_2 = 0.5 \sigma_1$	12.6	14.0	17.4	23.4
$\sigma_2 = \sigma_1$ hydrostatic tension	12.6	13.5	13.5	12.6
$\sigma_2 = -\sigma_1$ pure shear	12.6	39.0	39.0	64.4

Table B10-2. Maximum Deflections and Moments in Simply Supported Square Plate With a Circular Hole Subjected to Uniform Load

R/b	W_{\max}	Max M_{θ}
	$\frac{qb^4}{D}$	qb^2
0	0.649	0.192
1/6	0.0719	0.344
1/3	0.0697	0.276
1/2	0.0530	0.207
2/3	0.0303	0.143
5/6	0.0119	0.085
1	0.00268	0.036

Table B10-3. Maximum Deflections and Moments in a Clamped Square Plate With a Circular Hole Subjected to Uniform Load

R/b	W_{\max}	Max M_{θ} along the hole	Max M_n along the edge
	$\frac{qb^4}{D}$	qb^2	qb^2
0	0.02025	0.0916	-0.2055
1/6	0.02148	0.1451	-0.2032
1/3	0.01648	0.0907	-0.1837
1/2	0.00858	0.0522	-0.1374
2/3	0.00307	0.0310	-0.0780
5/6	0.00081	0.0176	-0.0410
1	0.00025	0.0067	-0.0215

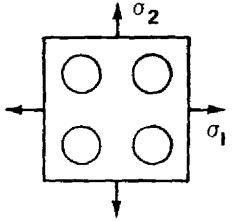
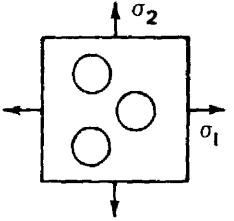
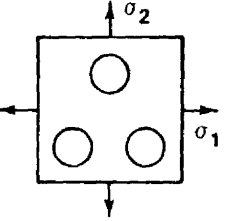
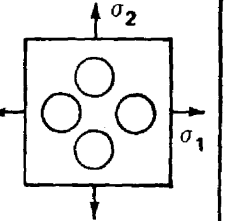
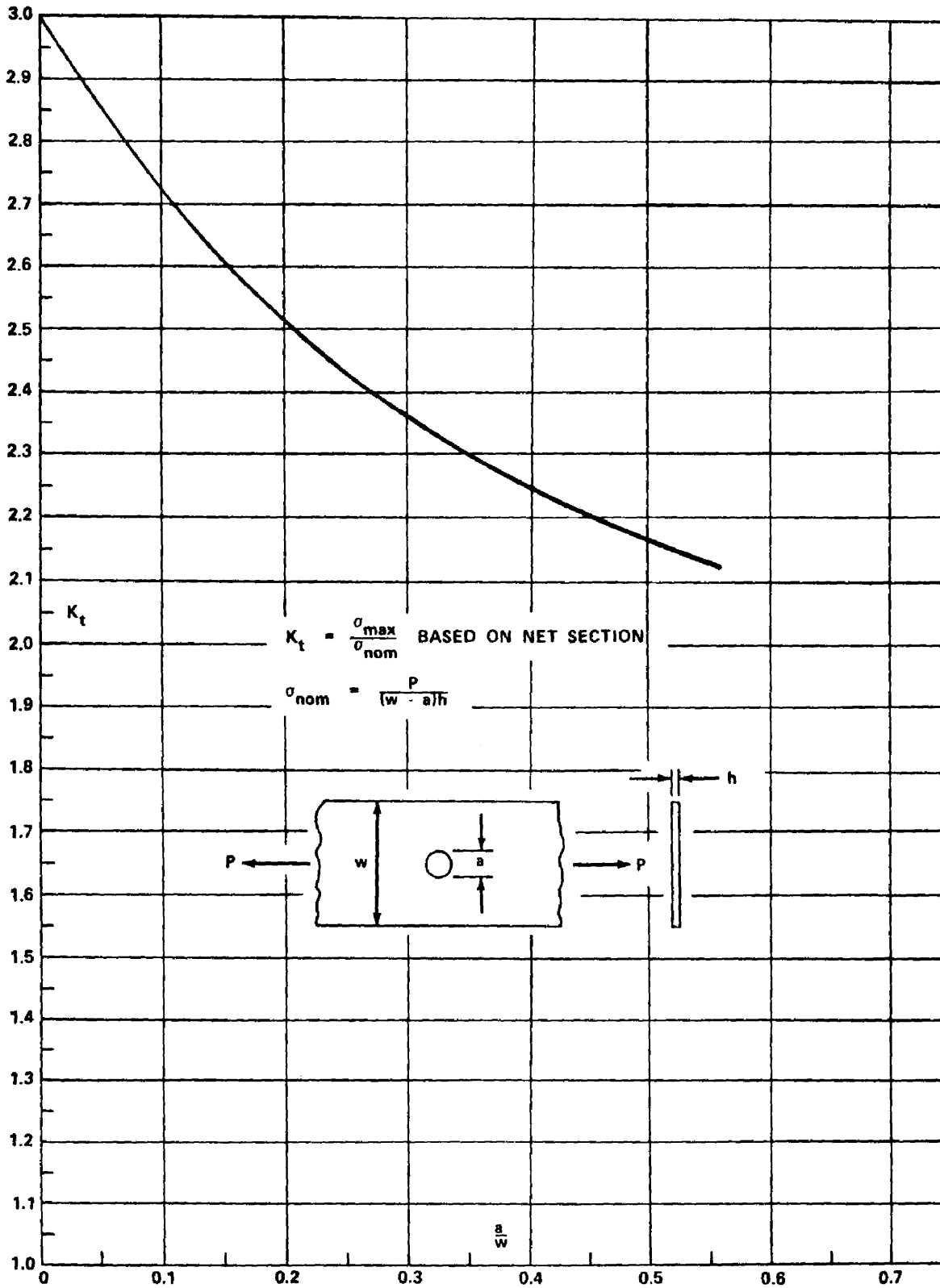

FIGURE B10-1. STRESS CONCENTRATION FACTOR, K_t , FOR AXIAL LOADING CASE OF A FINITE-WIDTH PLATE WITH A TRANSVERSE HOLE.

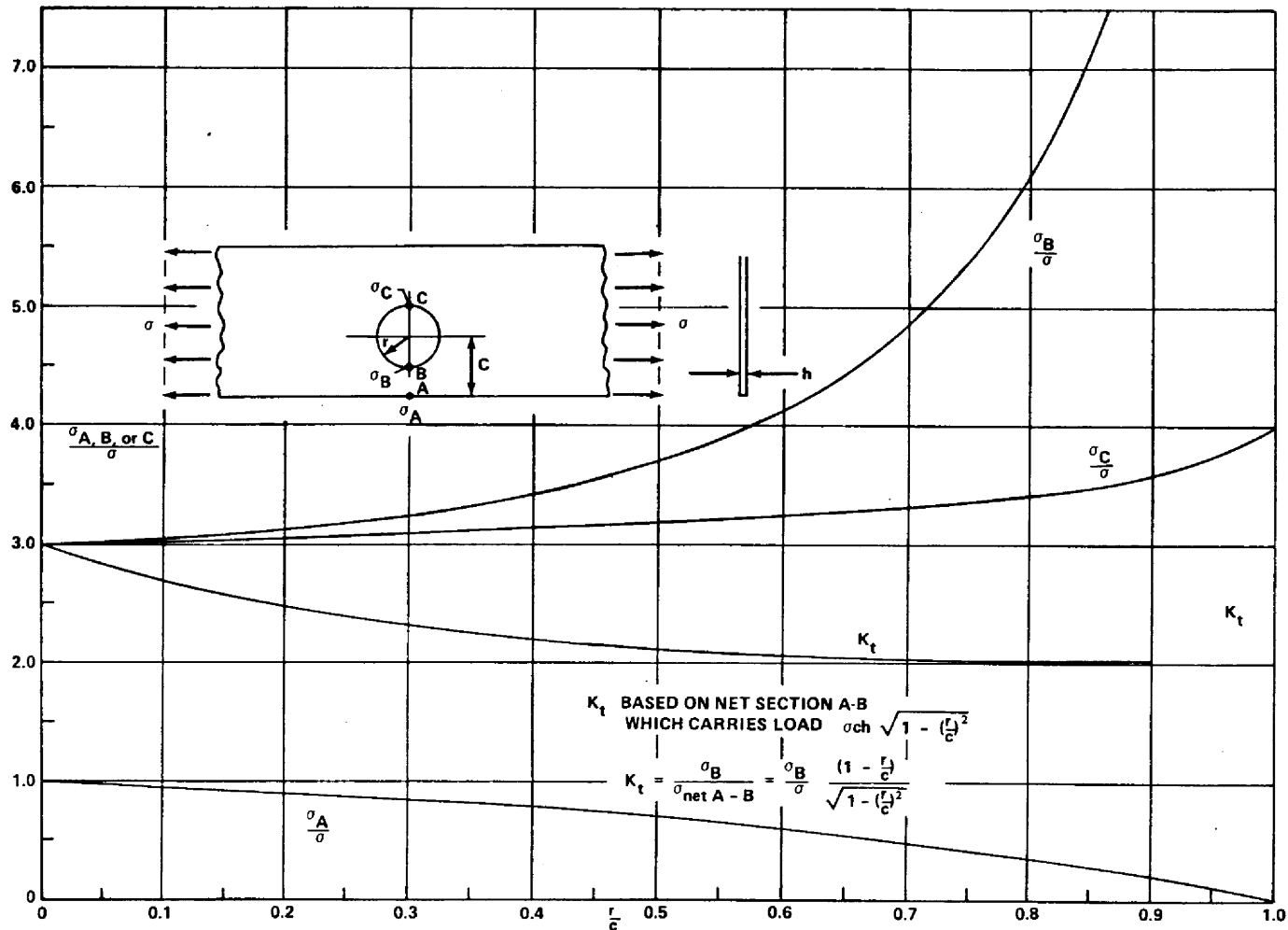

FIGURE B10-2. STRESS CONCENTRATION FACTOR, K_t , FOR THE TENSION CASE OF A SEMI-INFINITE PLATE WITH A CIRCULAR HOLE NEAR THE EDGE.

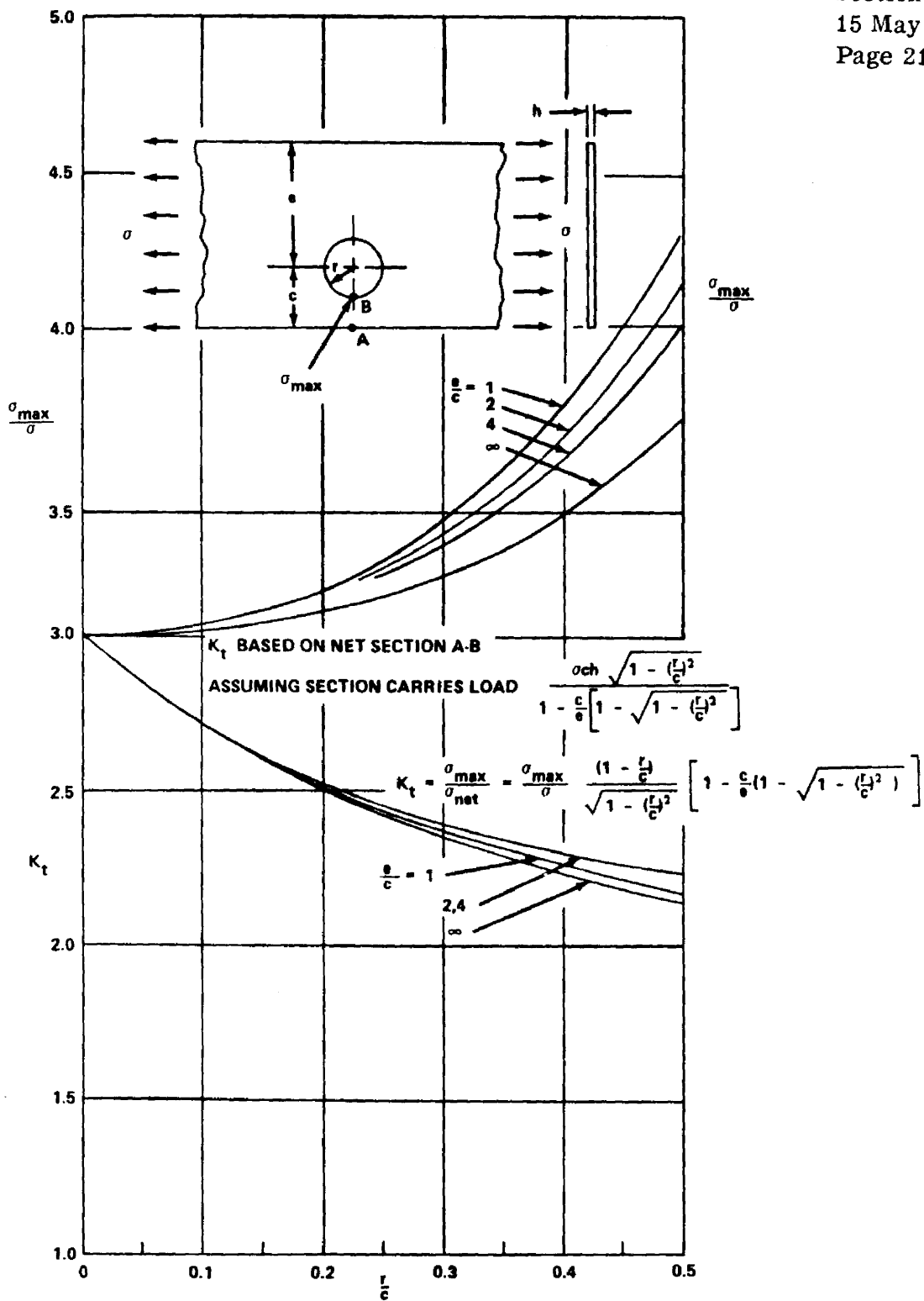

FIGURE B10-3. STRESS CONCENTRATION FACTOR, K_t , FOR TENSION CASE OF A FLAT BAR WITH A CIRCULAR HOLE DISPLACED FROM CENTER LINE.

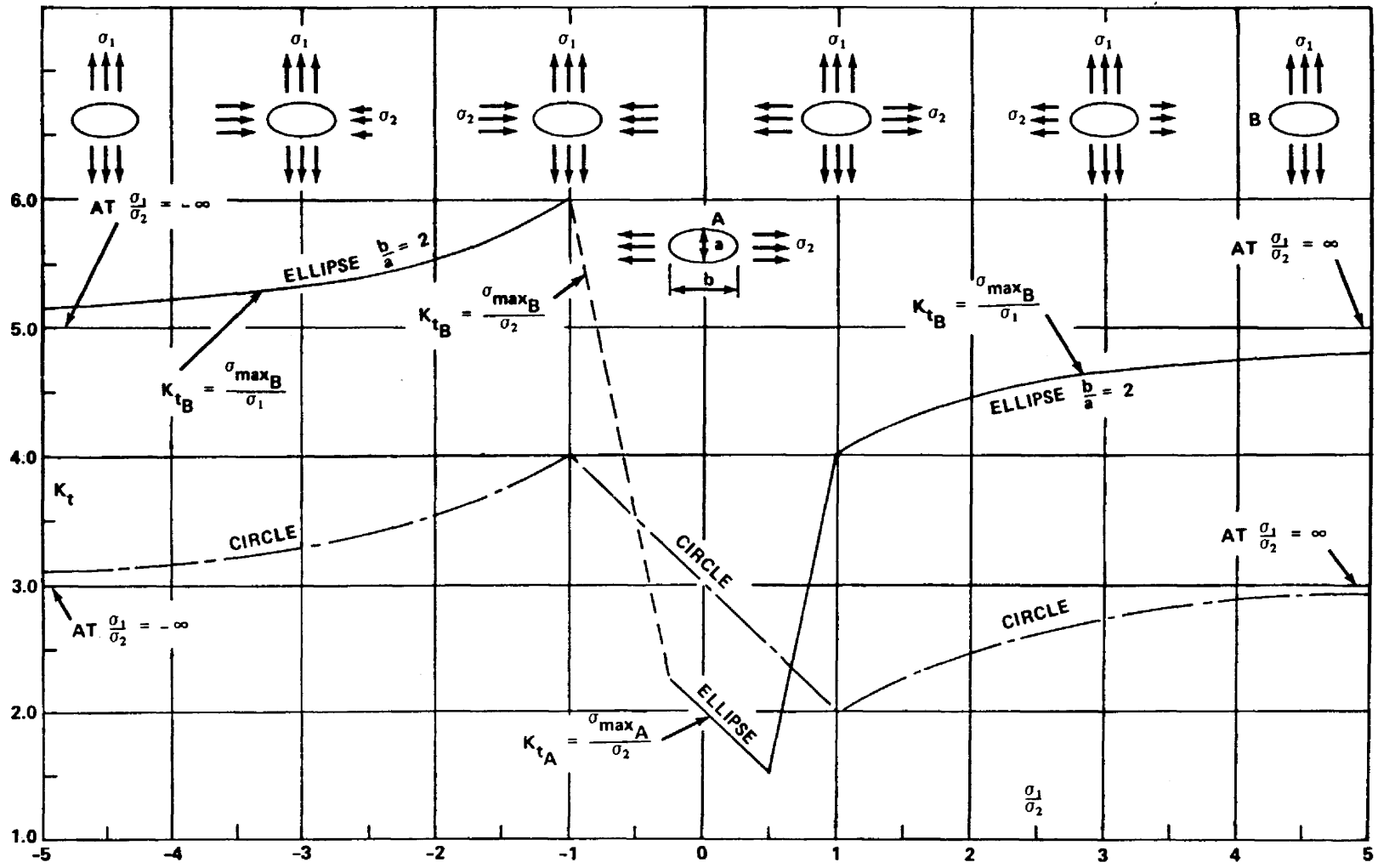

FIGURE B10-4. STRESS CONCENTRATION FACTOR, K_t , FOR AN ELLIPTICAL HOLE $\frac{b}{a} = 2$ AND FOR A CIRCULAR HOLE IN A PLATE SUBJECTED TO BIAXIAL STRESS.

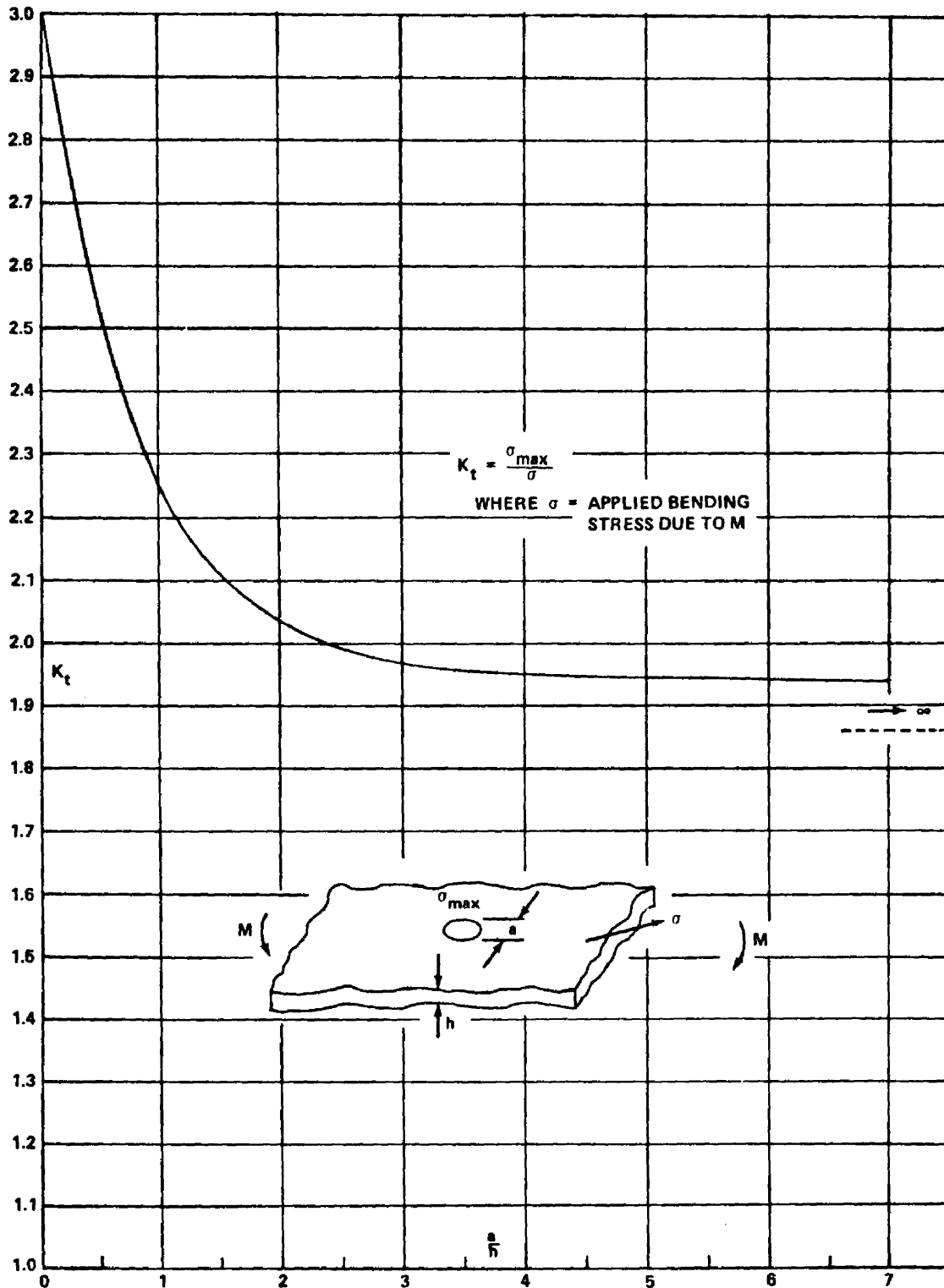

FIGURE B10-5. STRESS CONCENTRATION FACTOR, K_t ,
 FOR BENDING CASE OF AN INFINITELY WIDE
 PLATE WITH A TRANSVERSE HOLE.

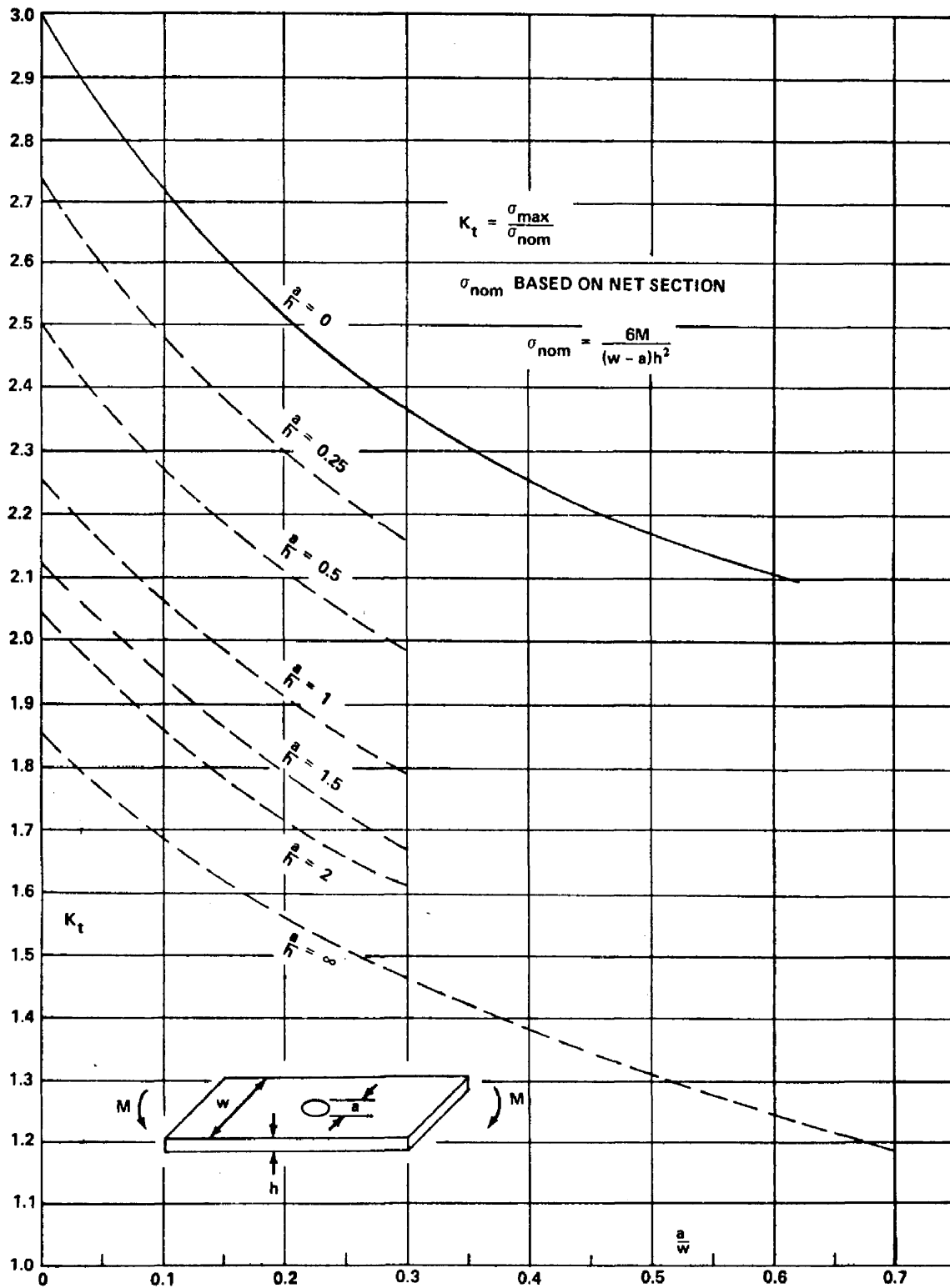

FIGURE B10-6. STRESS CONCENTRATION FACTOR, K_t ,
 FOR BENDING CASE OF FINITE-WIDTH PLATE
 WITH A TRANSVERSE HOLE.

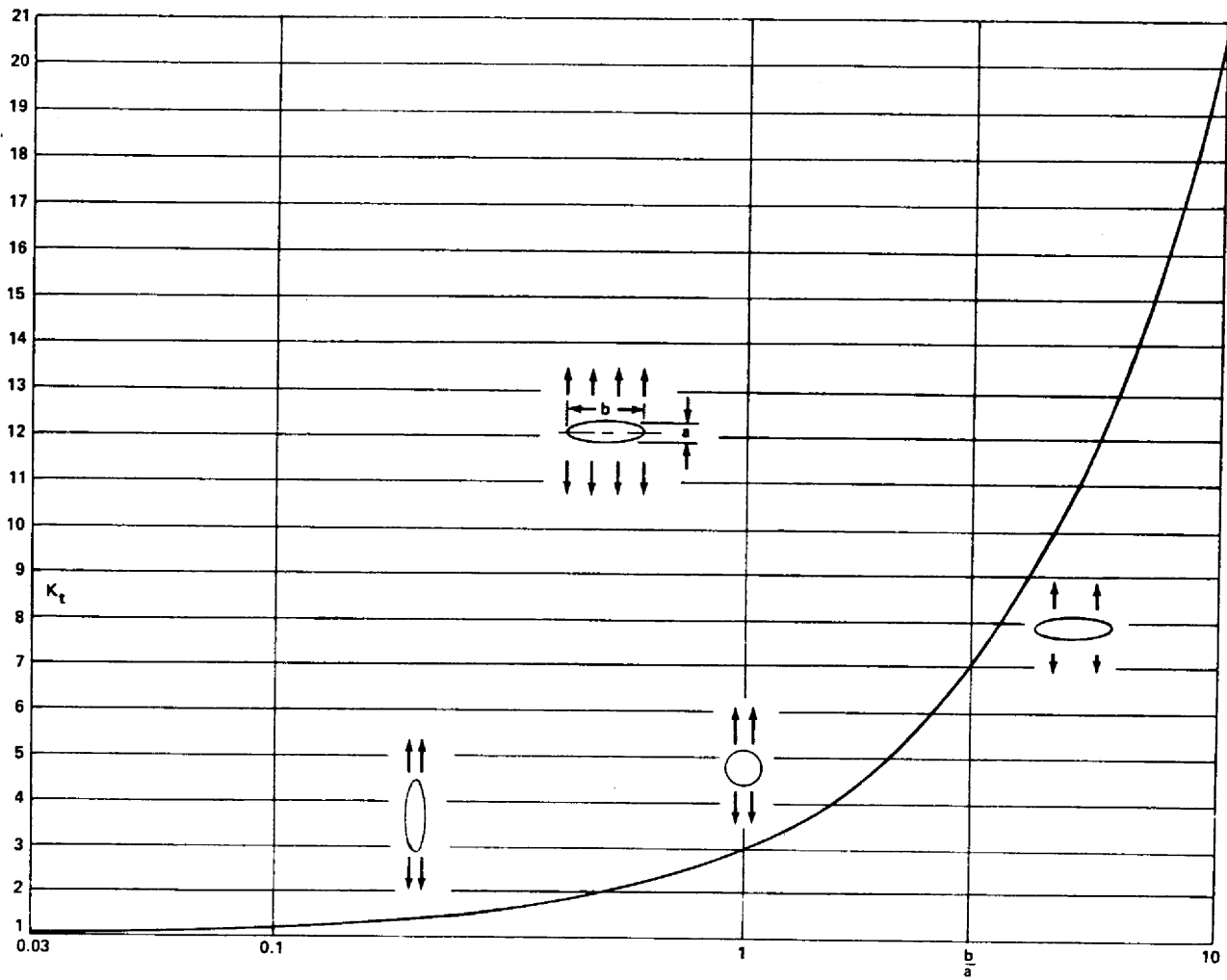

FIGURE B10-7. STRESS CONCENTRATION FACTOR, K_t , FOR AN ELLIPTICAL HOLE IN AN INFINITE PLATE IN TENSION.

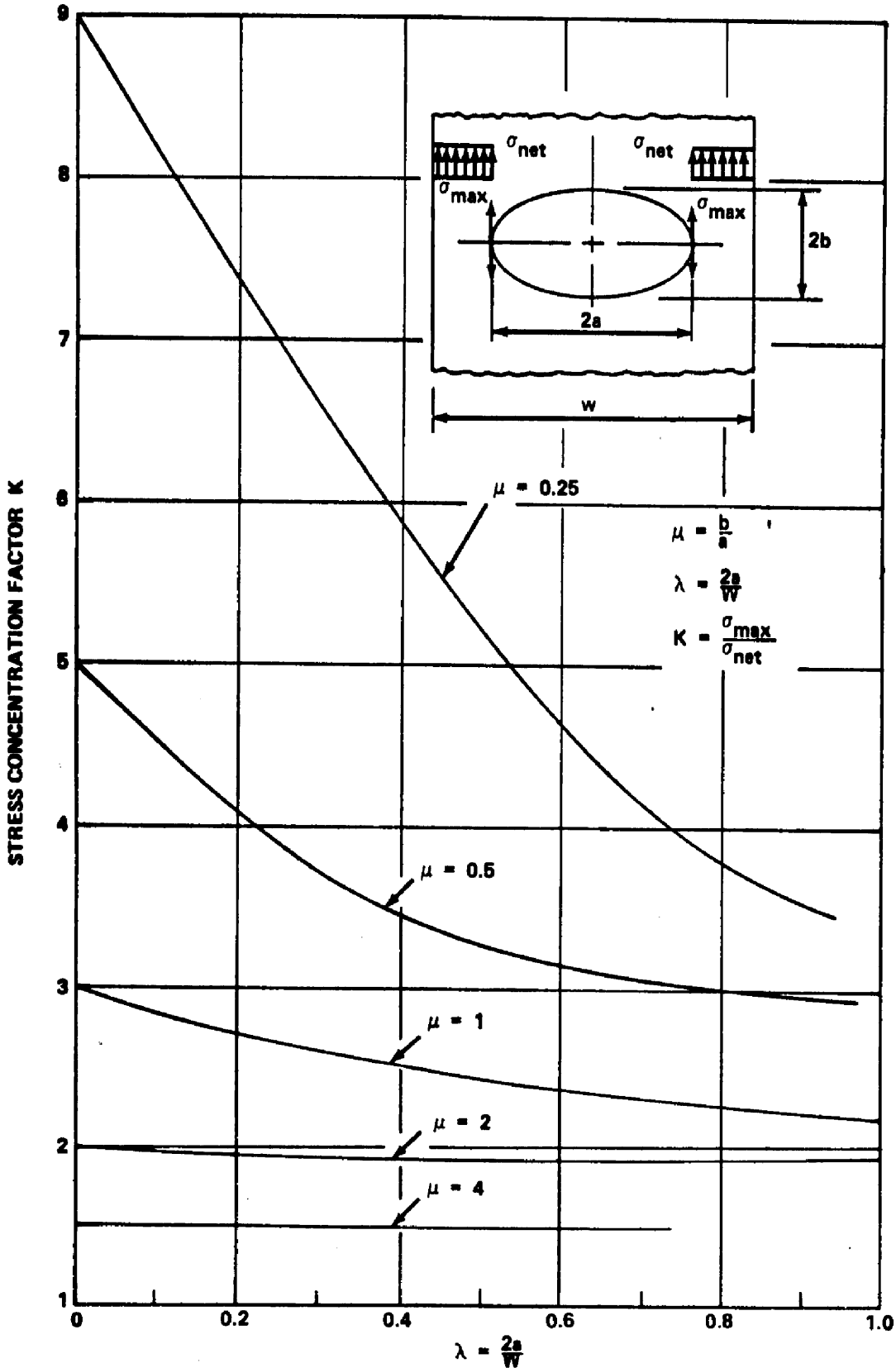

FIGURE B10-8. STRESS CONCENTRATION FACTOR FOR POINTS UNDER MAXIMUM TENSION IN A FINITE PLATE WITH AN ELLIPTICAL HOLE.

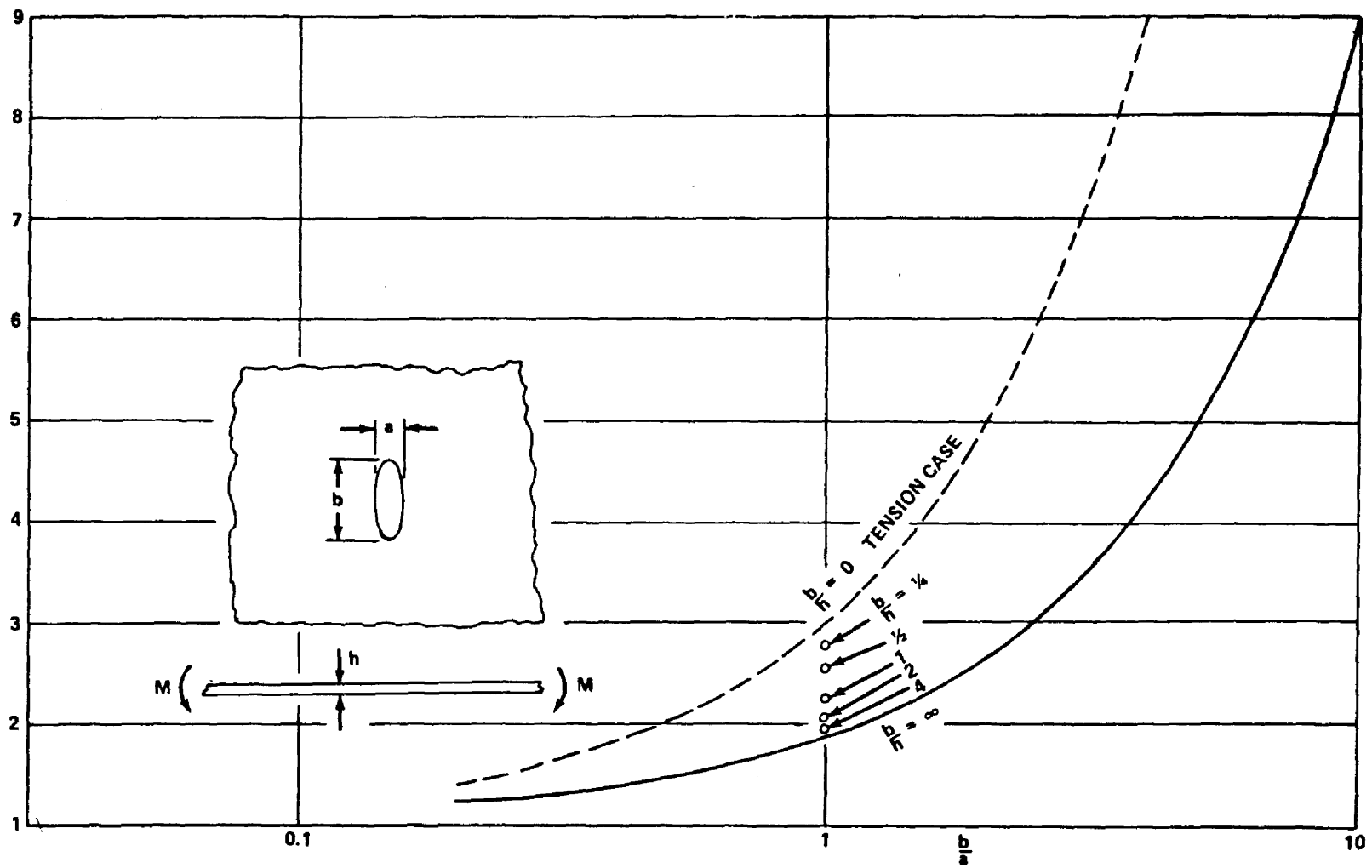

FIGURE B10-9. STRESS CONCENTRATION FACTOR, K_t , FOR THE TRANSVERSE BENDING CASE OF AN INFINITELY WIDE SHEET CONTAINING AN ELLIPTICAL HOLE.

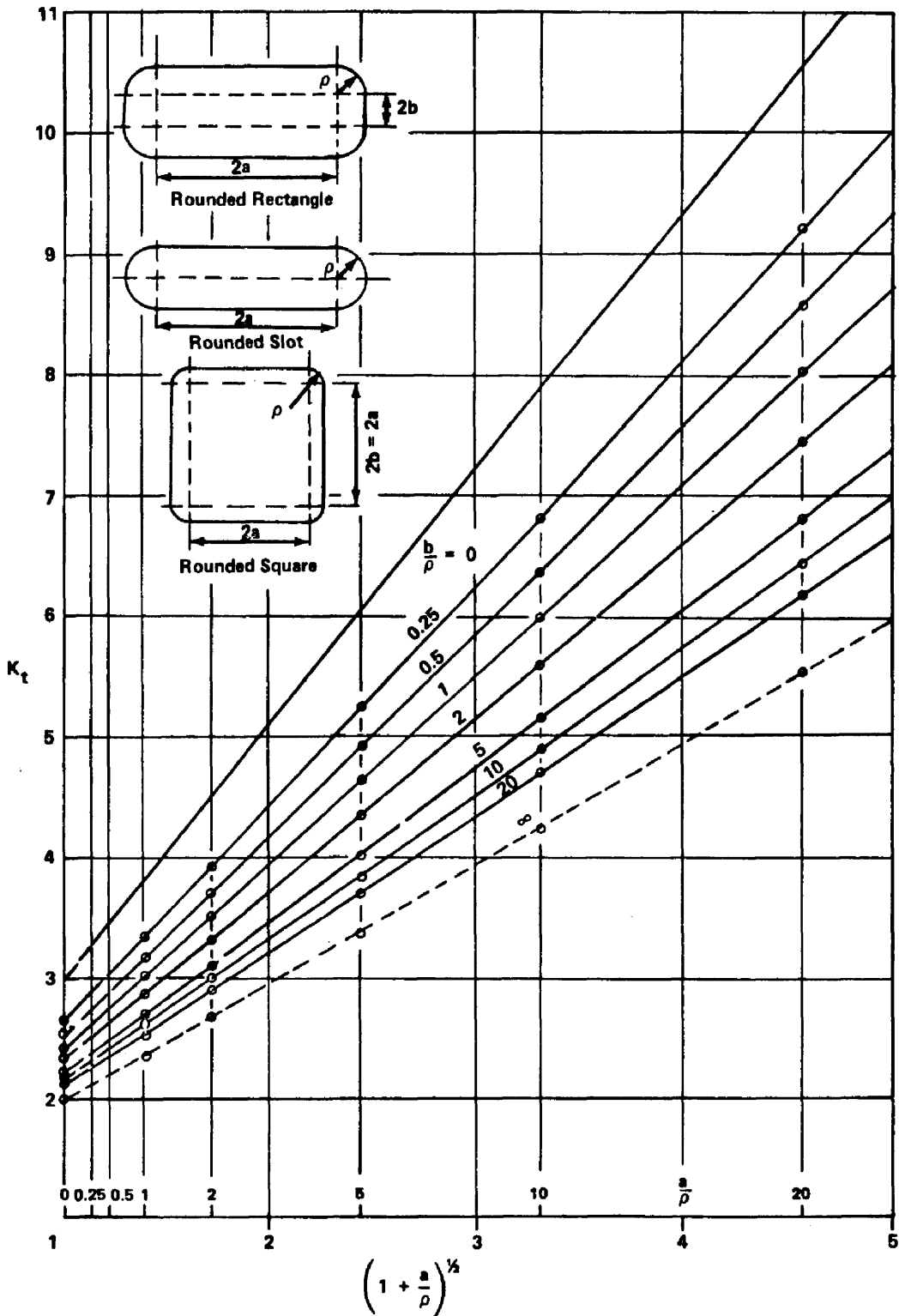

FIGURE B10-10. VARIATION OF K_t WITH $\frac{a}{\rho}$ FOR CONSTANT $\frac{b}{\rho}$ WITH TENSILE LOADING TENDING TO OPEN THE SLOT.

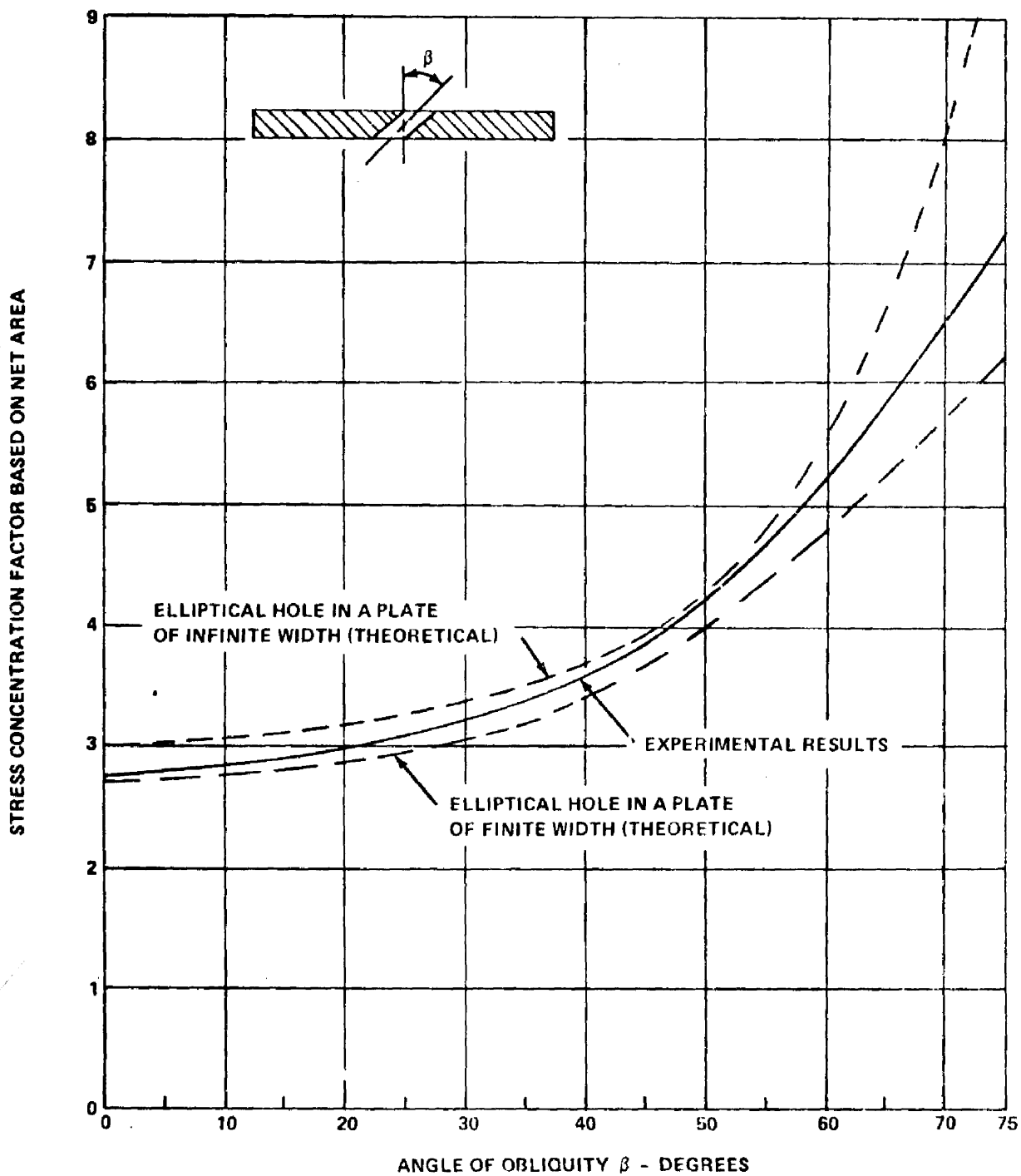

FIGURE B10-11. STRESS CONCENTRATION FACTOR BASED ON NET AREA AS A FUNCTION OF ANGLE OF OBLIQUITY β .

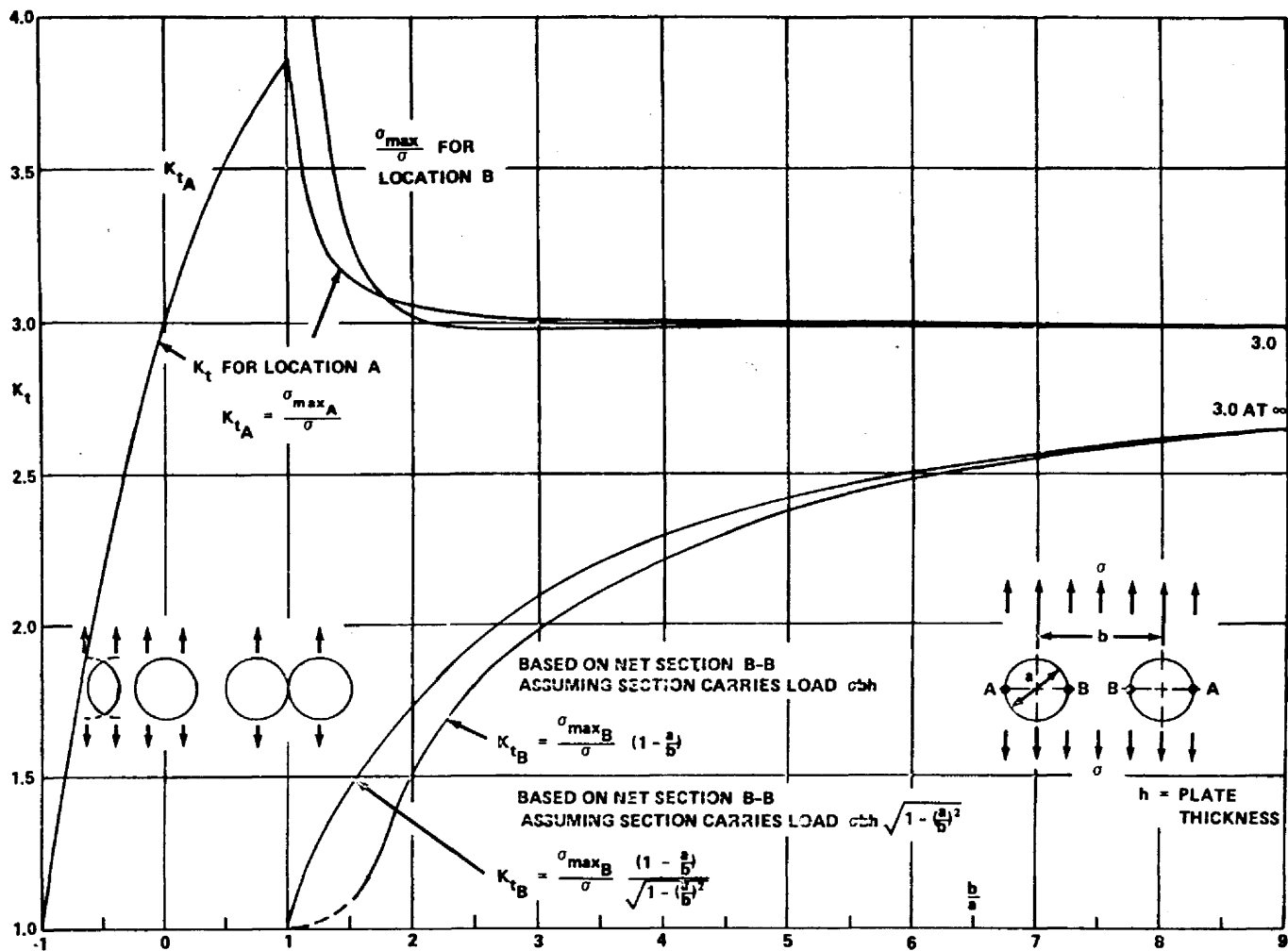

FIGURE B10-12. STRESS CONCENTRATION FACTOR, K_t , FOR TENSION CASE OF AN INFINITE PLATE WITH TWO CIRCULAR HOLES (TENSION PERPENDICULAR TO LINE OF HOLES).

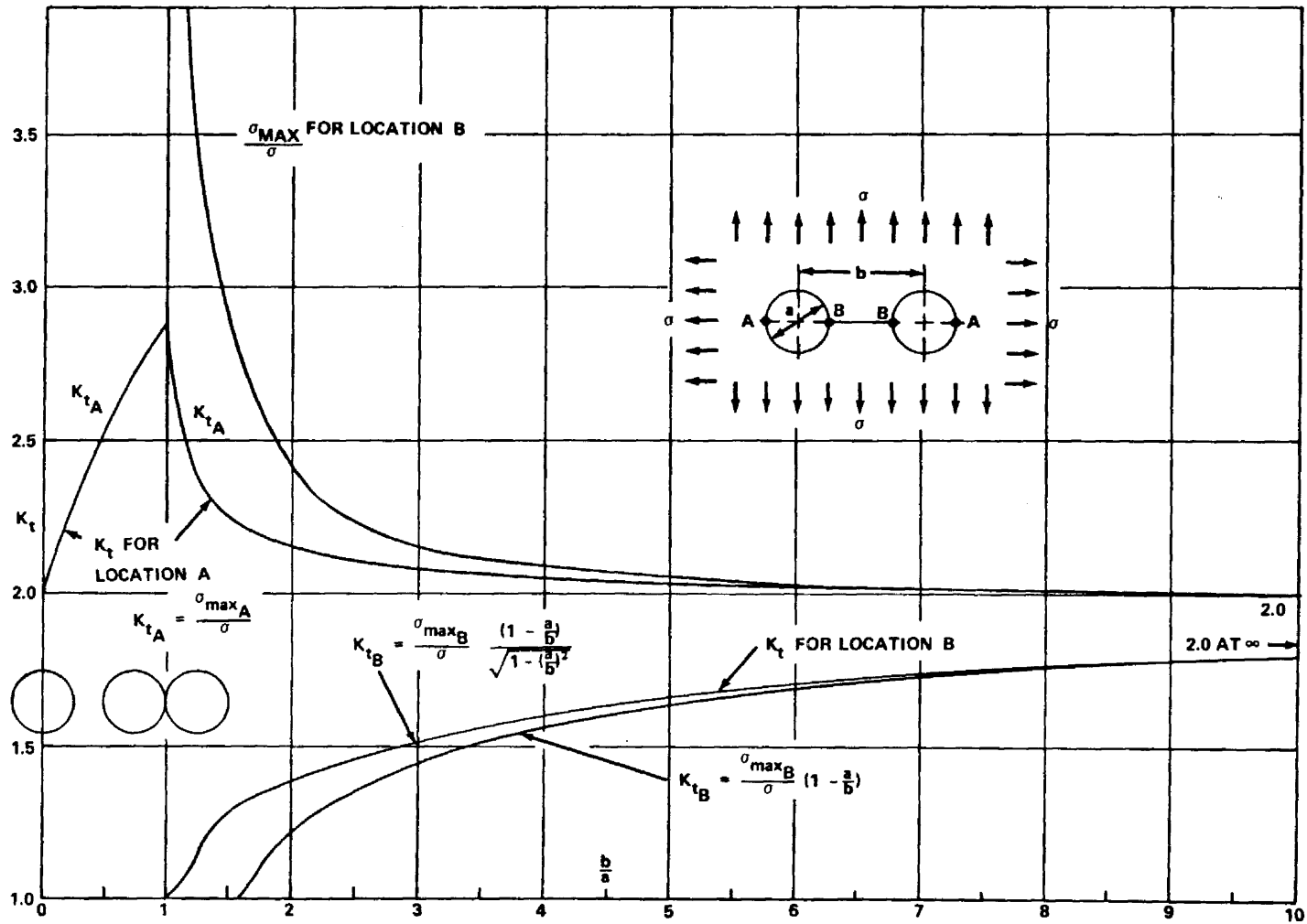

FIGURE B10-13. STRESS CONCENTRATION FACTOR, K_t , FOR BIAxIAL TENSION CASE OF AN INFINITE PLATE WITH TWO CIRCULAR HOLES.

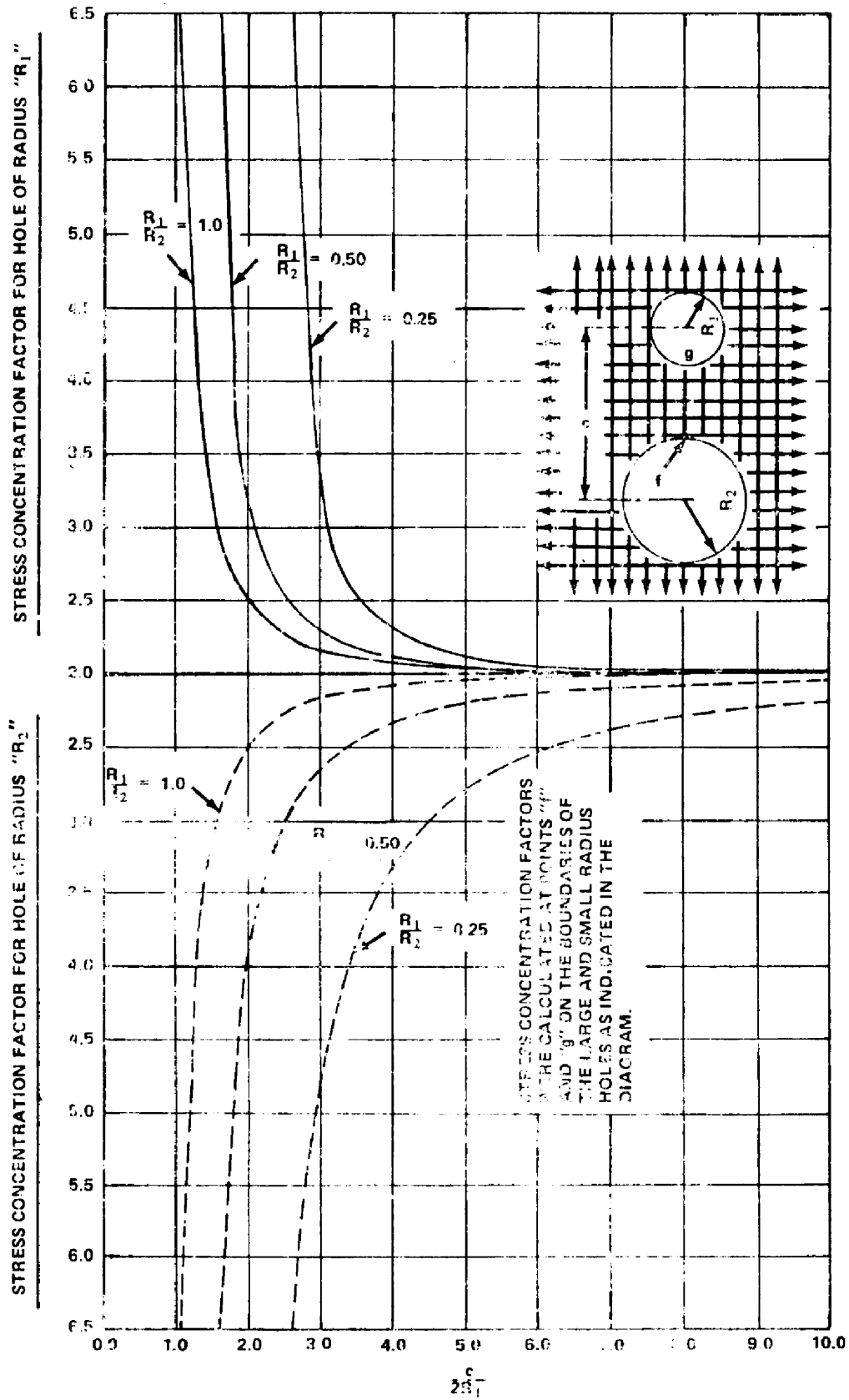

FIGURE B10-14. STRESS CONCENTRATION FACTORS FOR TWO UNEQUAL-SIZED HOLES IN BLAXIAL FIELD OF STRESS.

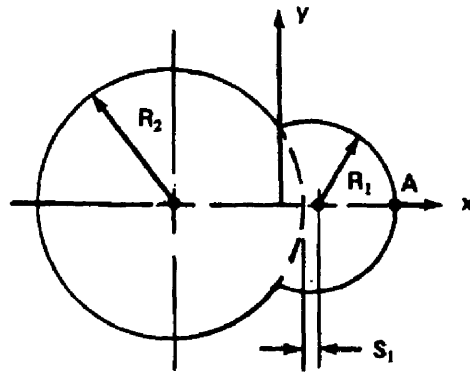

FIGURE B10-15. HOLE WITH CIRCULAR NOTCH.

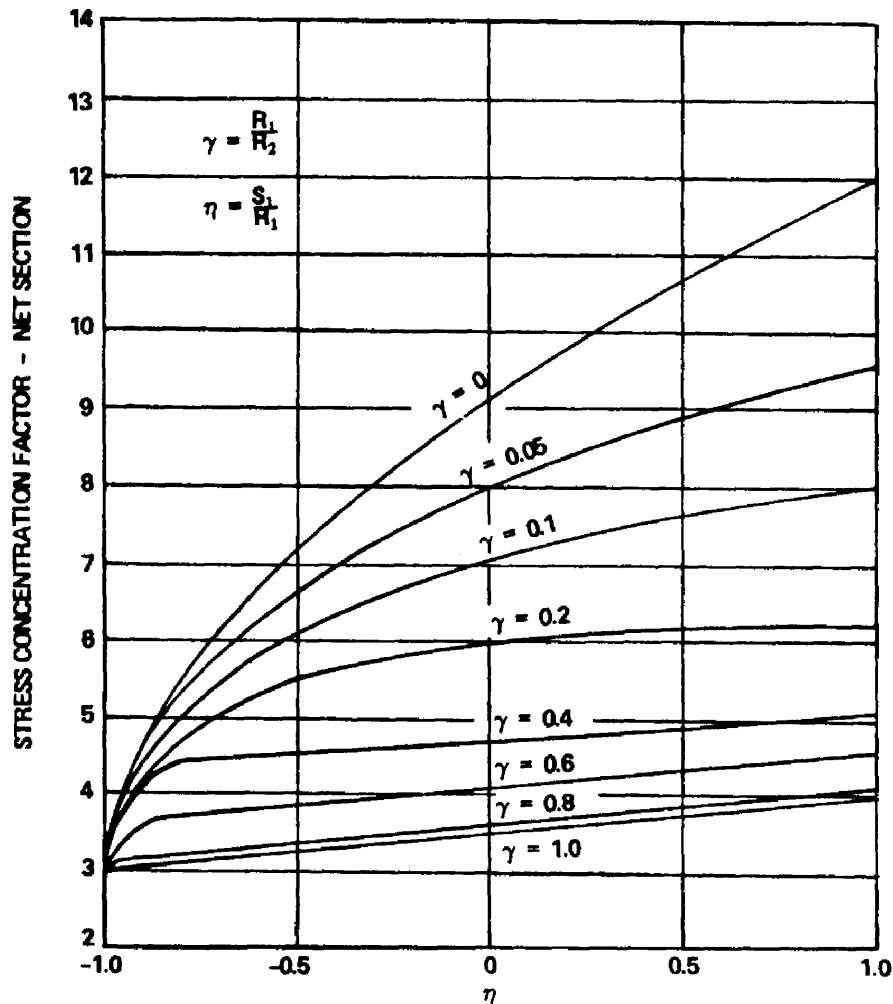

FIGURE B10-16. STRESS CONCENTRATION FACTOR AT POINT A UNDER TENSION IN Y-DIRECTION.

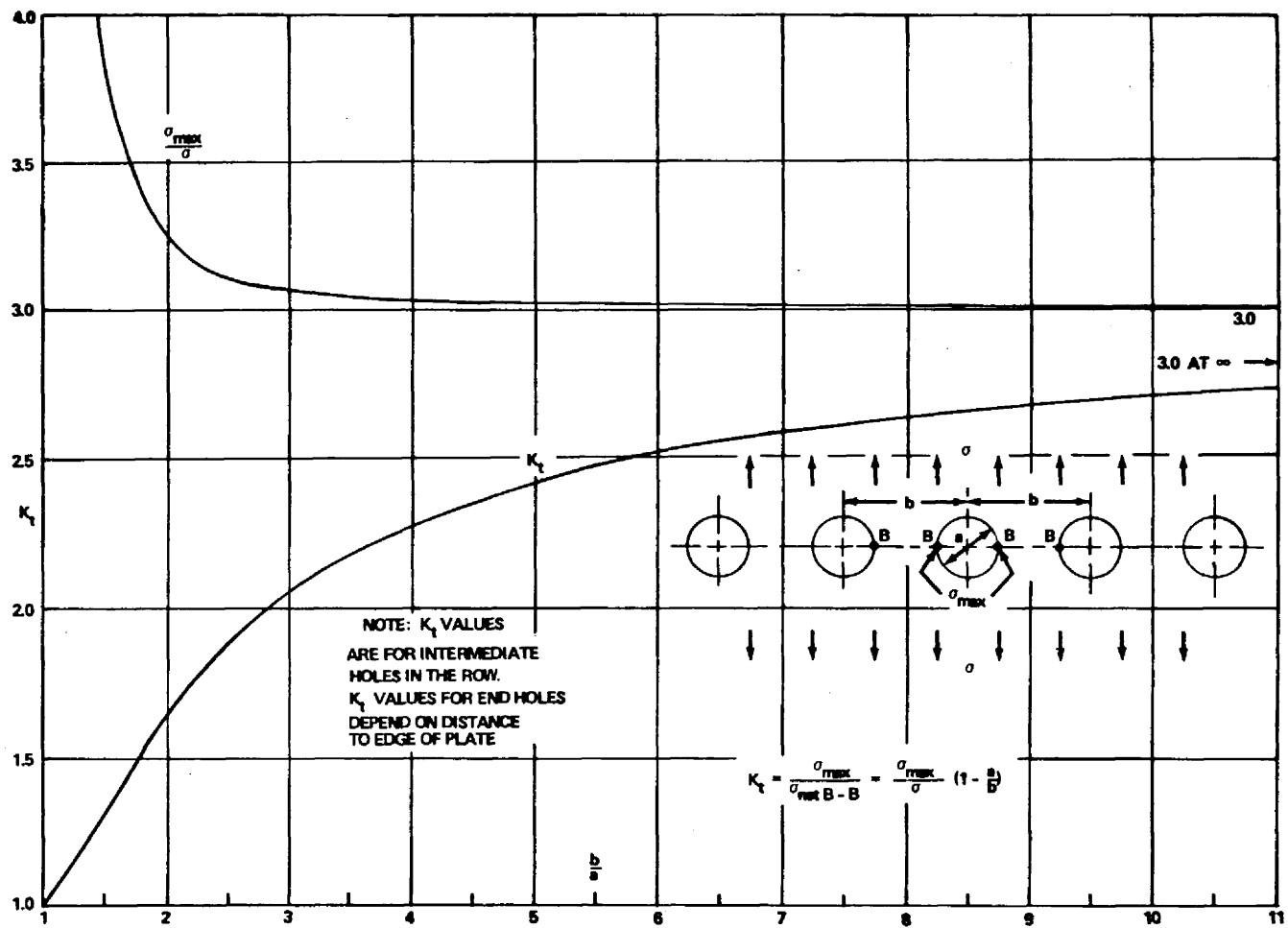

FIGURE B10-17. STRESS CONCENTRATION FACTOR, K_t , FOR TENSION CASE OF A SHEET WITH A SINGLE ROW OF HOLES. (TENSION PERPENDICULAR TO LINE OF HOLES.) K_t BASED ON NET SECTION.

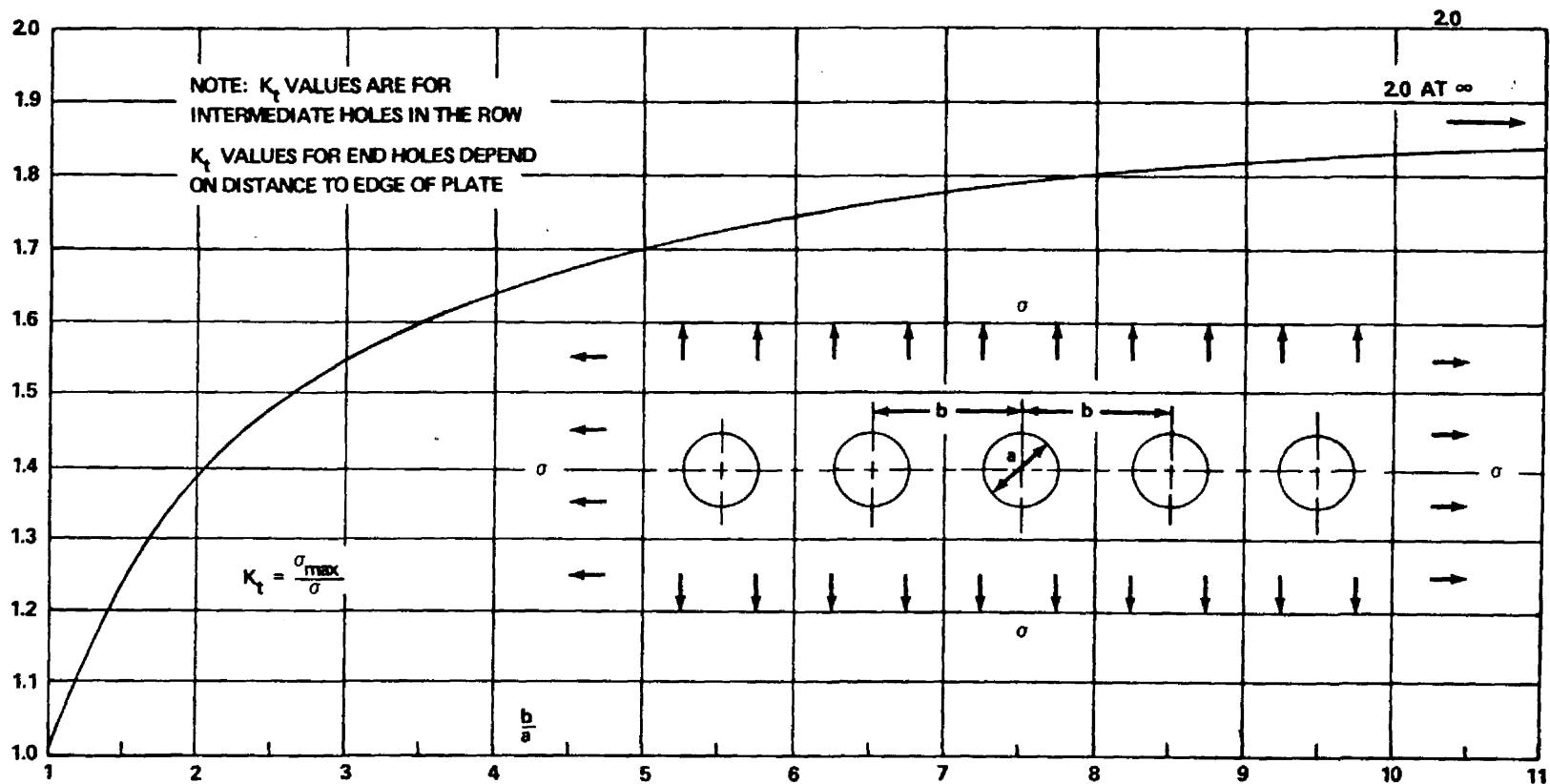
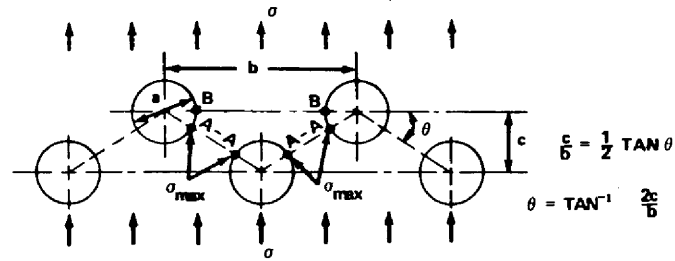

FIGURE B10-18. STRESS CONCENTRATION FACTOR, K_t , FOR A BIAXIALLY STRESSED INFINITELY WIDE PLATE CONTAINING A ROW OF HOLES.



$\frac{a}{b} = 0 \quad \frac{b}{a} = \infty$ (INFINITE DISTANCE BETWEEN HOLES)

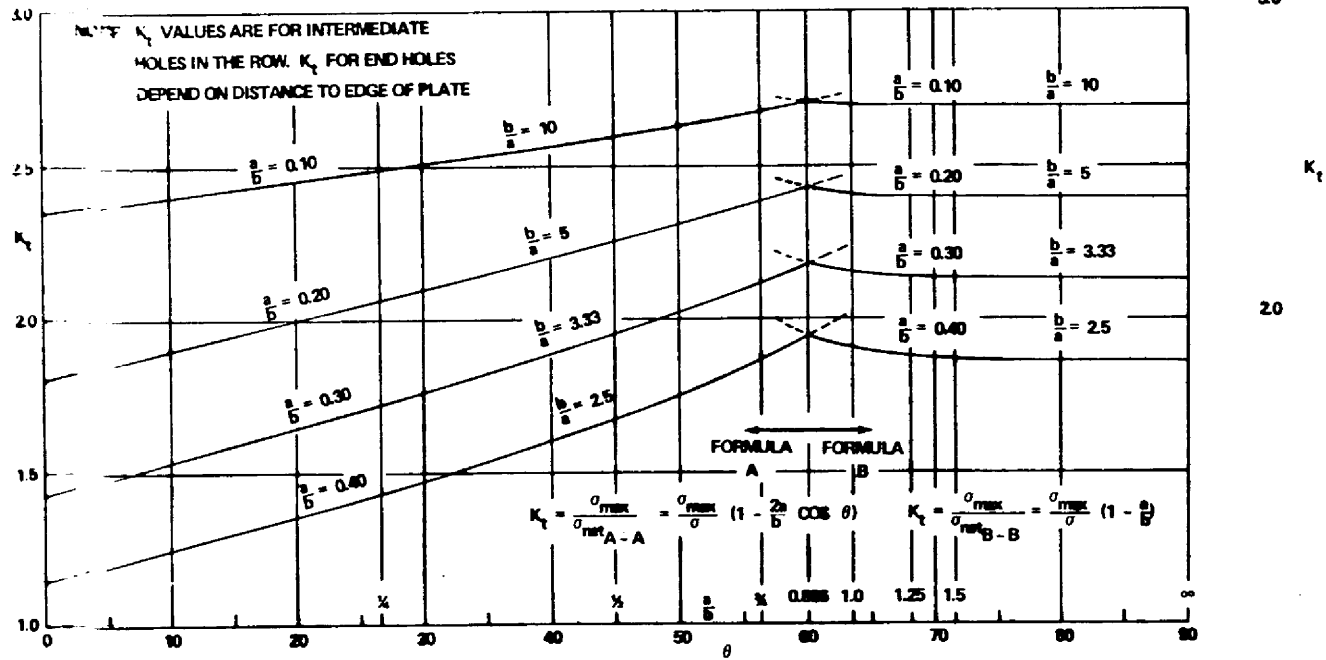

FIGURE B10-19. STRESS CONCENTRATION FACTOR, K_t , FOR TENSION CASE OF A SHEET WITH DOUBLE ROW OF HOLES. K_t BASED ON MINIMUM NET SECTION.

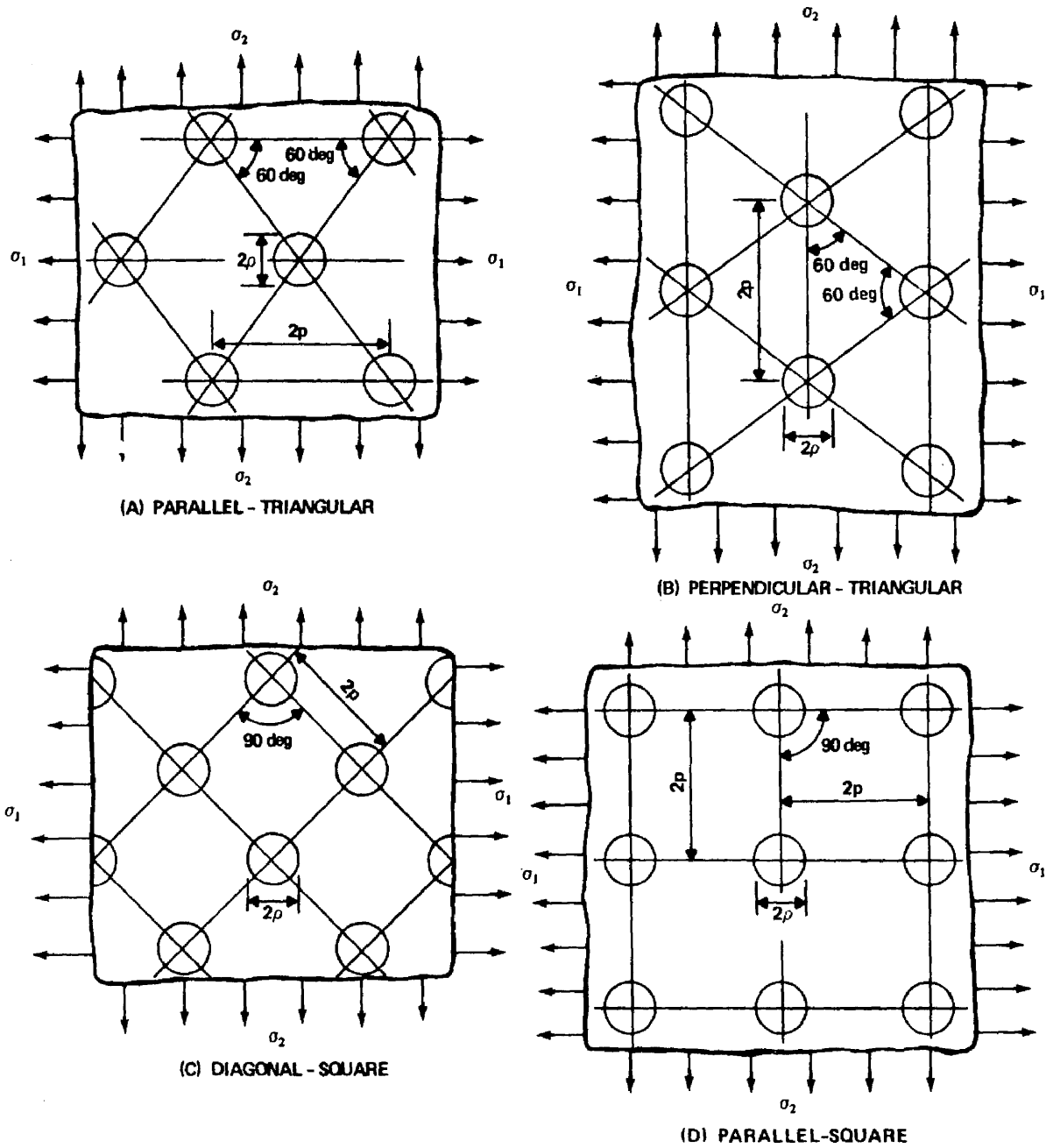

FIGURE B10-20. HOLE CONFIGURATIONS.

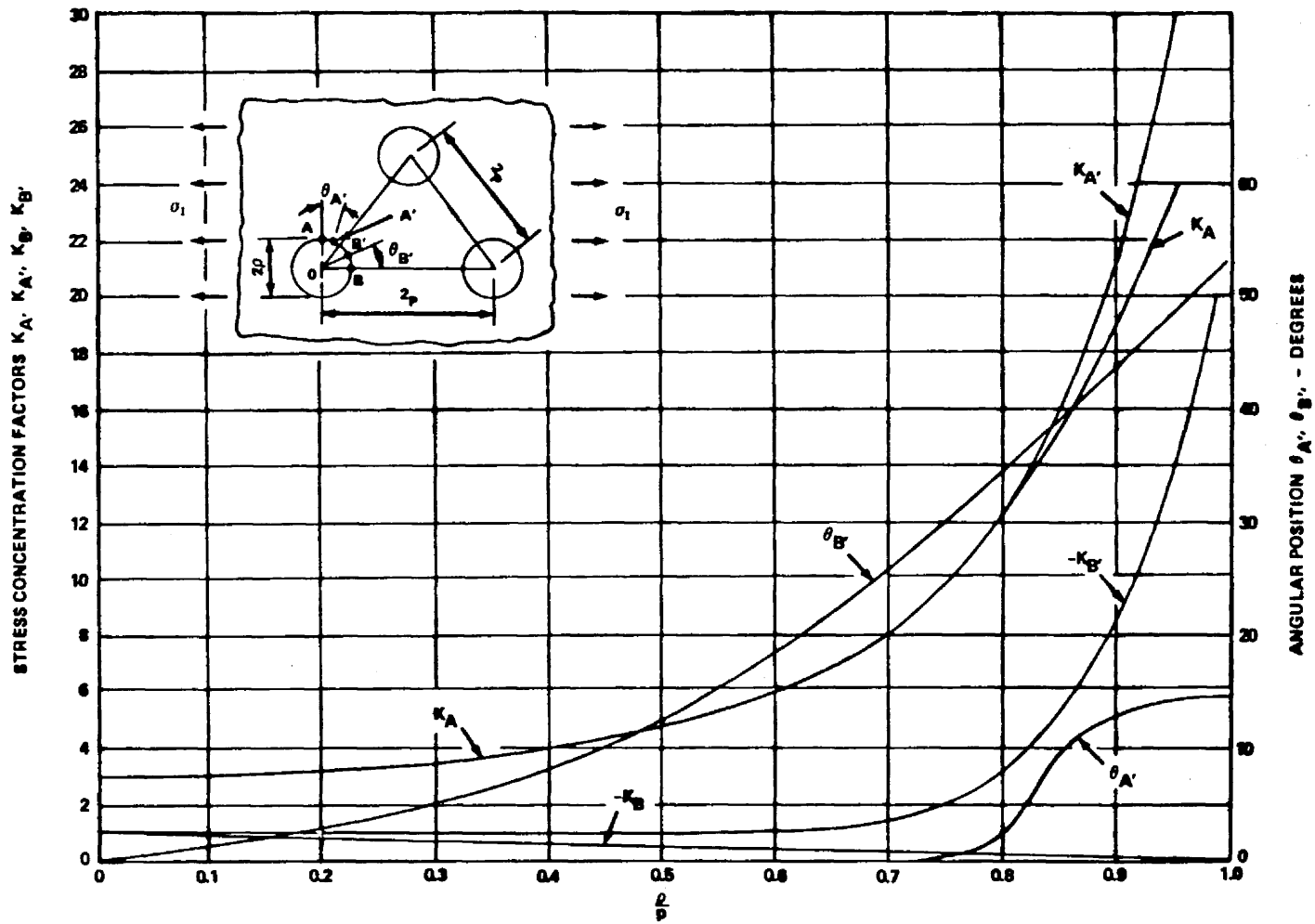

FIGURE B10-21. STRESS CONCENTRATION FACTORS FOR UNIAXIAL TENSION AND PARALLEL-TRIANGULAR HOLE CONFIGURATION.

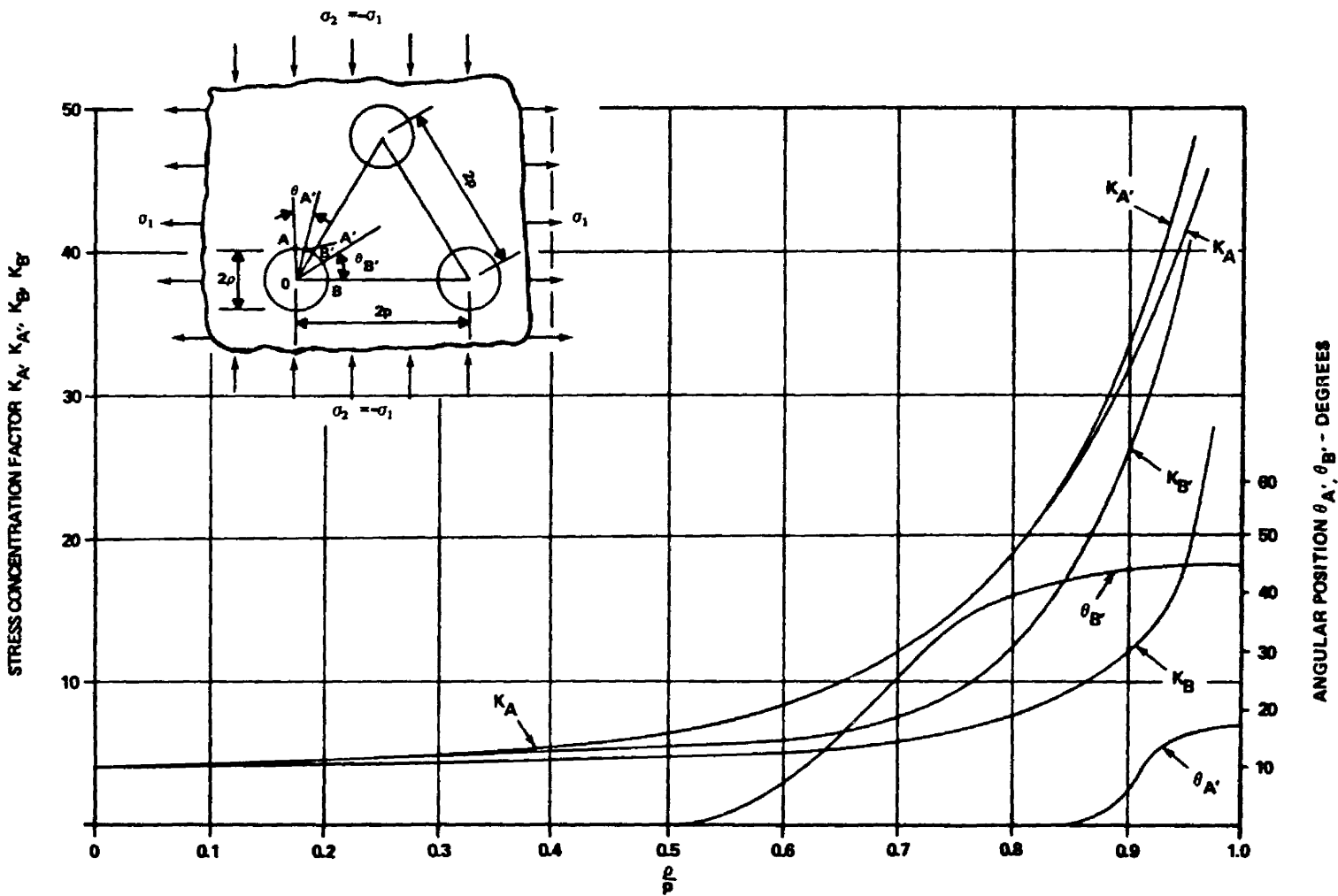

FIGURE B10-22. STRESS CONCENTRATION FACTORS FOR PURE SHEAR AND PARALLEL-TRIANGULAR HOLE CONFIGURATION.

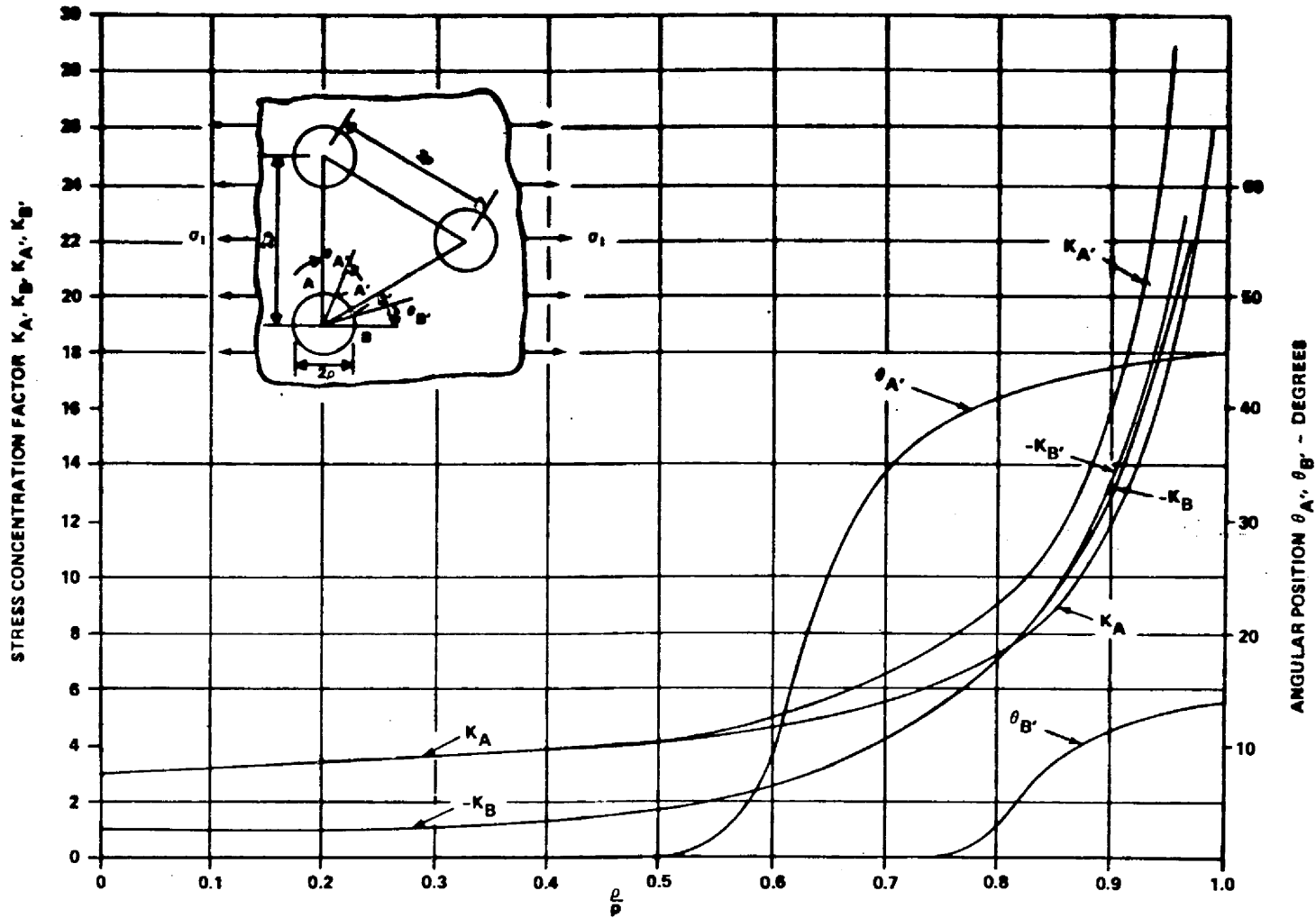

FIGURE B10-23. STRESS CONCENTRATION FACTORS FOR UNIAXIAL TENSION AND PERPENDICULAR-TRIANGULAR HOLE CONFIGURATION.

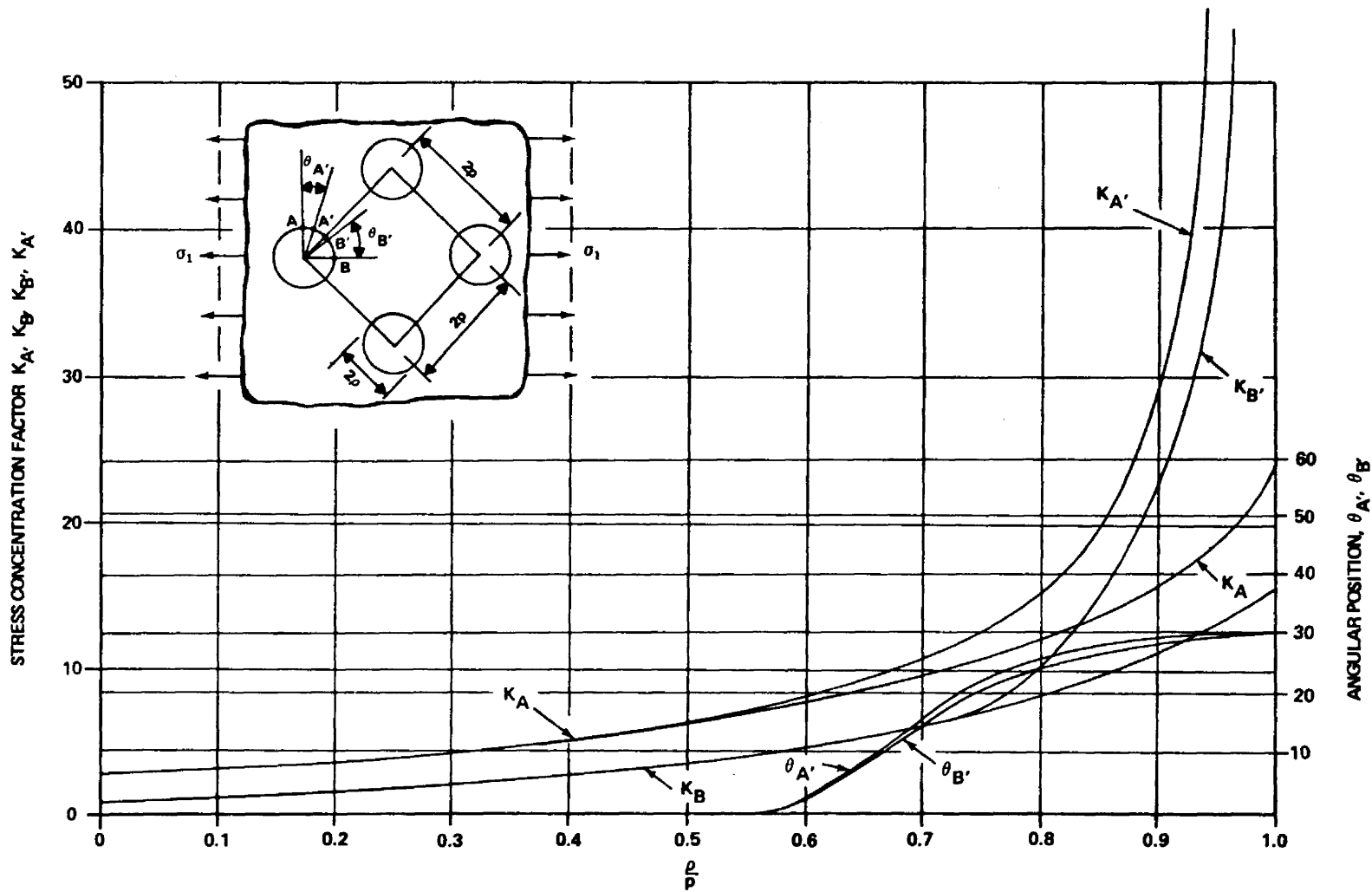

FIGURE B10-24. STRESS CONCENTRATION FACTORS FOR UNIAXIAL TENSION AND DIAGONAL-SQUARE HOLE CONFIGURATION.

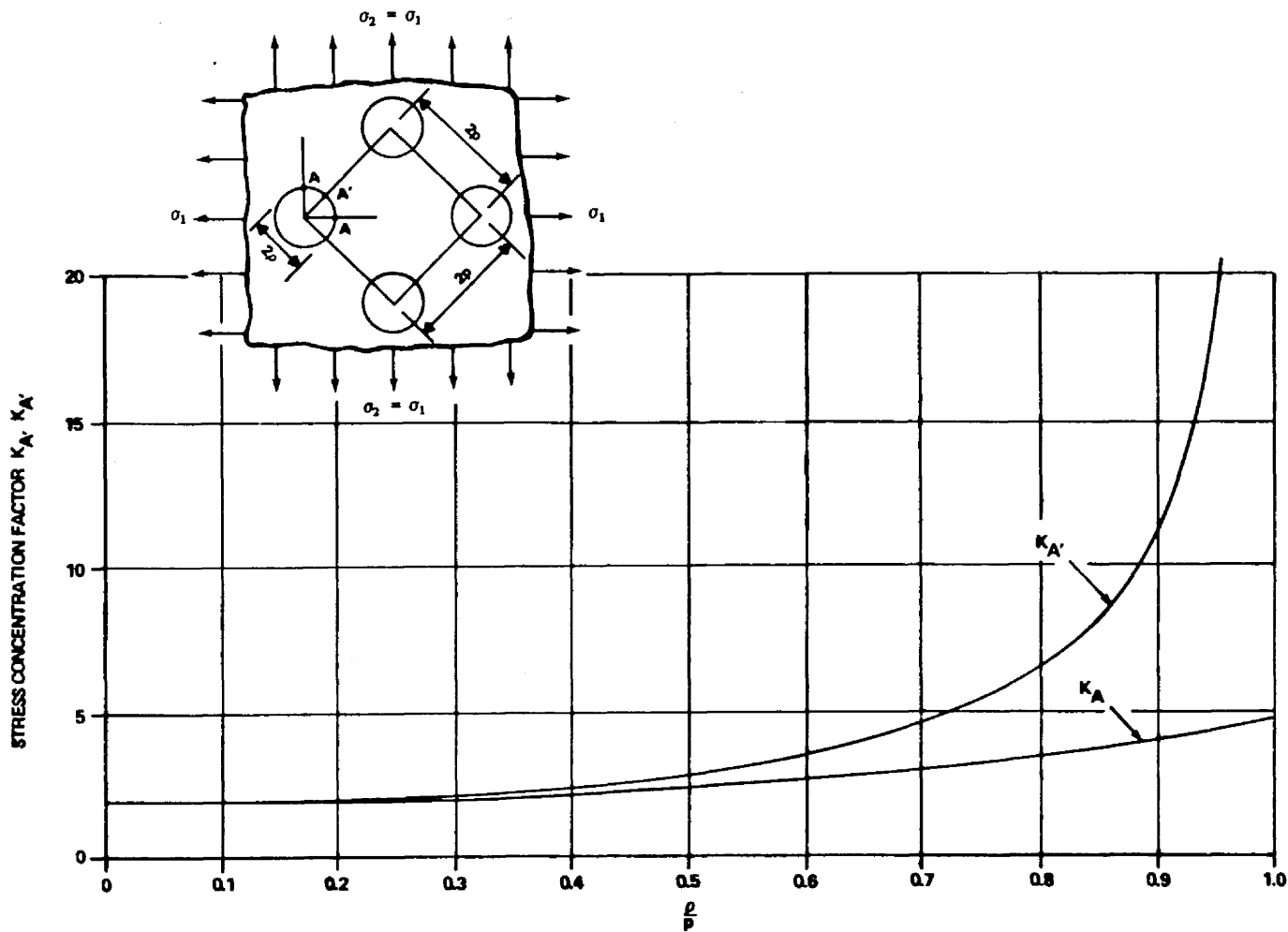

FIGURE B10-25. STRESS CONCENTRATION FACTORS FOR HYDROSTATIC TENSION FOR DIAGONAL-SQUARE HOLE CONFIGURATION.

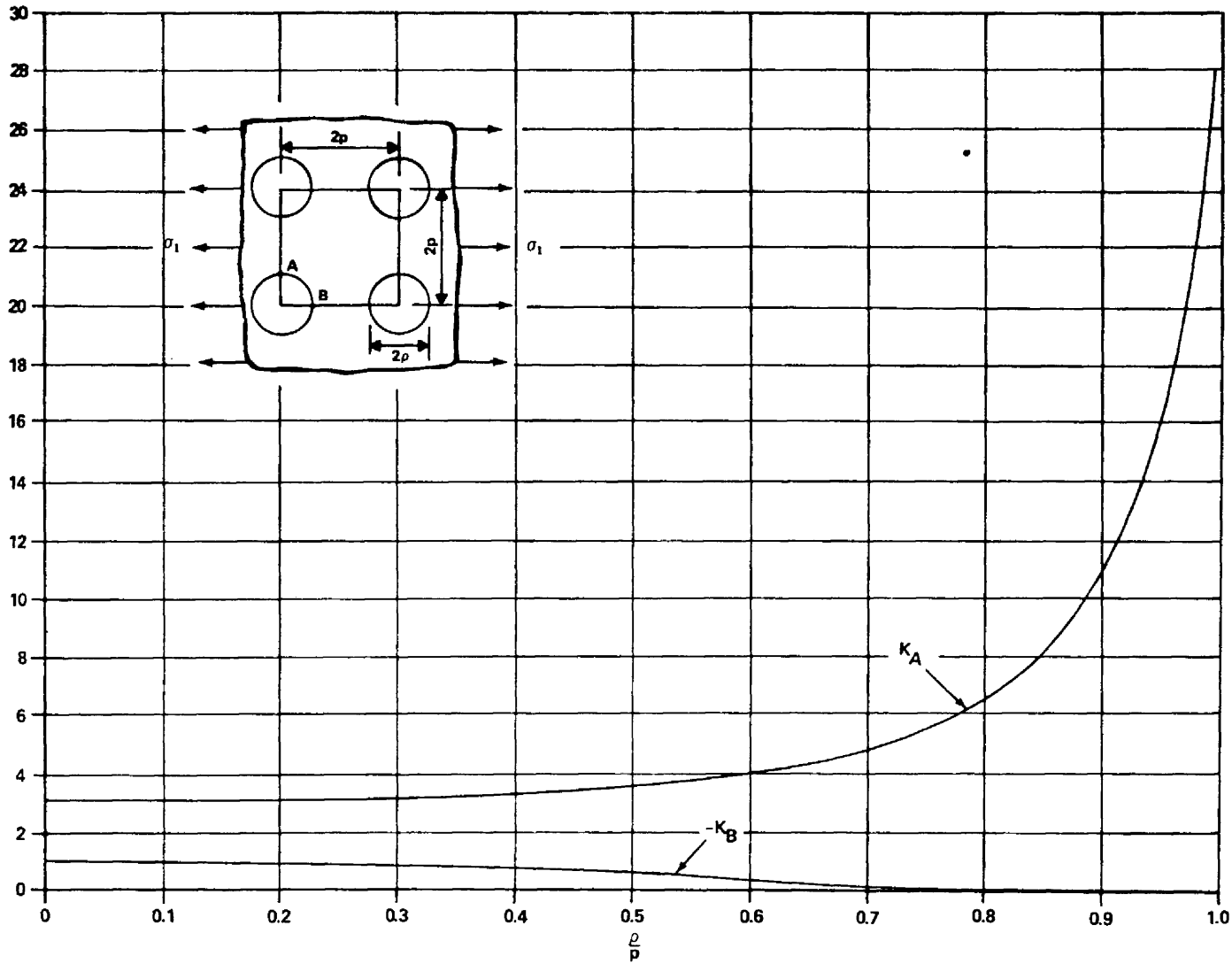

FIGURE B10-26. STRESS CONCENTRATION FACTORS FOR UNIAXIAL TENSION FOR PARALLEL-SQUARE HOLE CONFIGURATION.

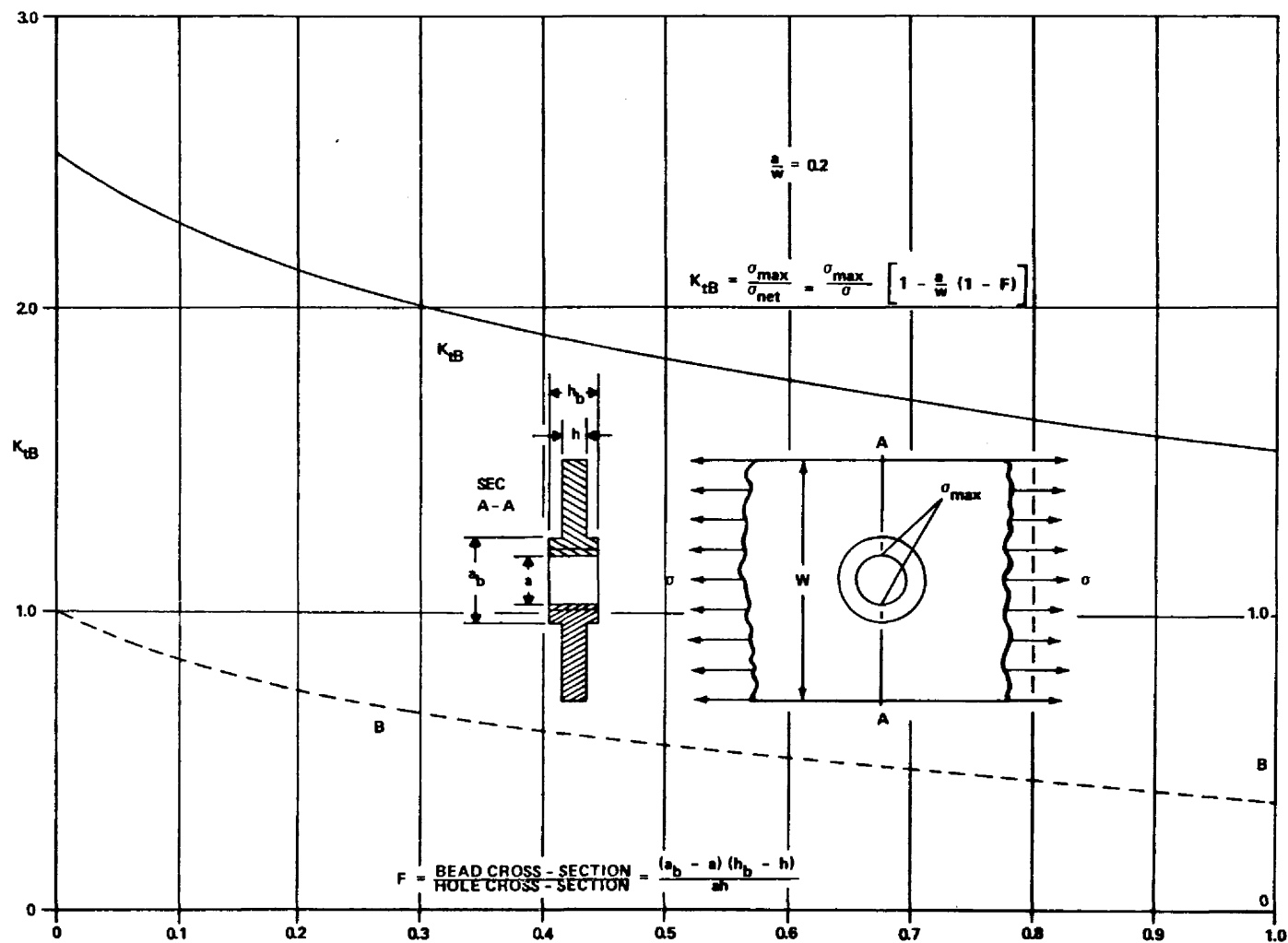

FIGURE B10-27. STRESS CONCENTRATION FACTOR, K_{tB} , FOR
A TENSION PLATE WITH A BEADED HOLE.

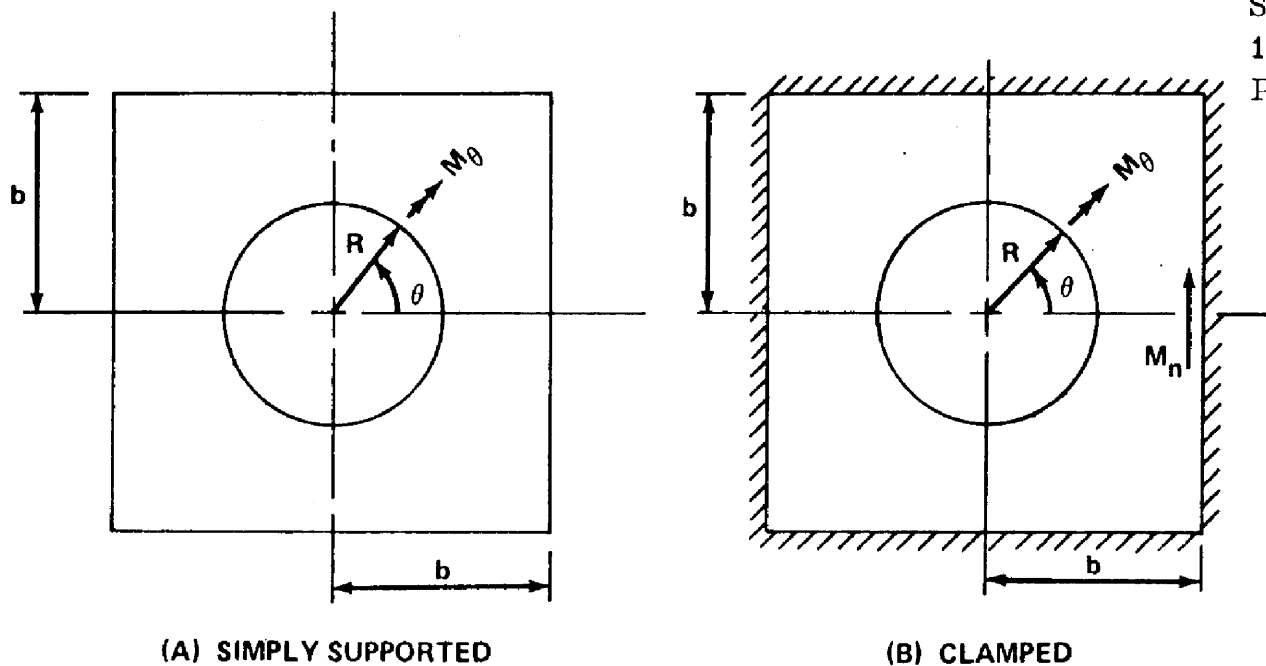

FIGURE B10-28. SQUARE PLATE WITH A CIRCULAR HOLE.

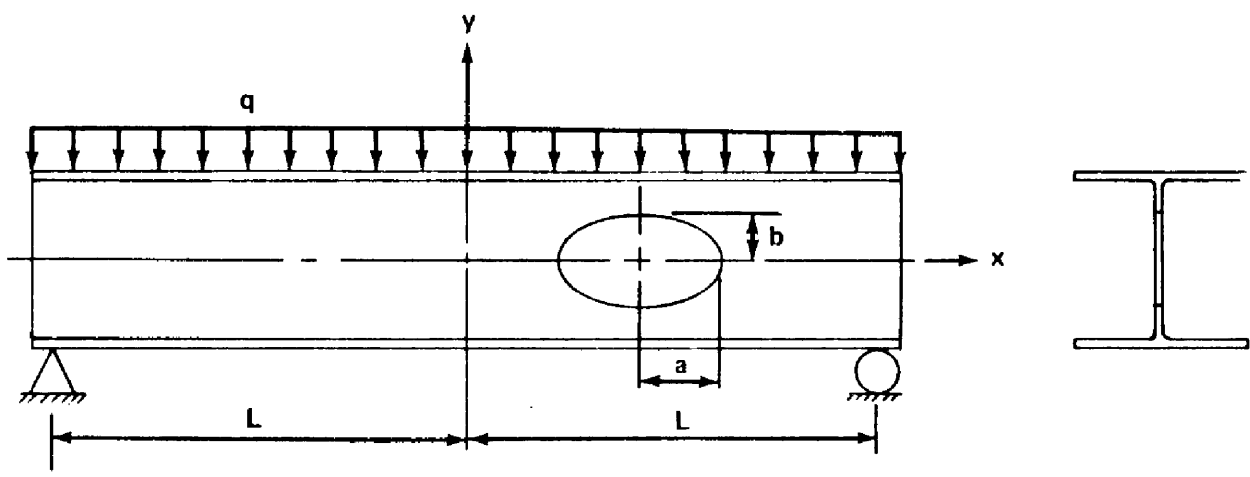

FIGURE B10-29. WIDE-FLANGE BEAM WITH A WEB HOLE.

BIBLIOGRAPHIES

Davies, G. A. O.: Stresses in a Square Plate Having a Central Circular Hole. Journal of the Royal Aeronautical Society, June 1965.

Hoddon, R. A. W.: Stresses in an Infinite Plate With Two Unequal Circular Holes. Quarterly Journal of Mechanics and Applied Mathematics, Vol. 20, Part 3, 1967.

Lerchenthal, C. H., and Talmor, R.: Reduction of Stress Concentration Near Circular Cutouts in a Tension Field Without Sheet Reinforcement.

Low, E. F., and Chang, W. F.: Stress Concentration Around Shaped Holes. Journal of the Engineering Mechanics Division, Proceedings of the American Society of Civil Engineers, June 1967.

Savin, G. N.: Elastic Stresses Around Holes in Wide-Flange Beams. Journal of the Structural Division, Proceedings of the American Society of Civil Engineers, April 1966.

REFERENCES

1. Sternberg, E., and Sadowsky, M. A.: Three-Dimensional Solution for the Stress Concentration Around a Circular Hole in a Plate of Arbitrary Thickness. Transactions of the ASME, Vol. 71, Applied Mechanics Section, 1949, p. 27.
2. Peterson, R. E.: Stress Concentration Design Factors. John Wiley and Sons, Inc., New York, 1959.
3. Durelli, A. J., Parks, V. J., and Feng, H. C.: Stresses Around an Elliptical Hole in a Finite Plate Subjected to Axial Loading. Journal of Applied Mechanics, Transactions of the ASME, March 1966.
4. Sobey, A. J.: Stress Concentration Factors for Rounded Rectangular Holes in Infinite Sheets. Royal Aircraft Establishment Report No. Structures 292, November 1963.
5. McKenzie, H. W., and White, D. J.: Stress Concentration Caused by an Oblique Round Hole in a Flat Plate Under Uniaxial Tension. Journal of Strain Analysis, Vol. 3, No. 2, 1968.
6. Ellyin, F., and Sherbourne, A. N.: Effect of Skew Penetration on Stress Concentration. Journal of the Engineering Mechanics Division, Proceedings of the ASCE, December 1968.
7. Salemo, V. L., and Mahoney, J. B.: Stress Solution for an Infinite Plate Containing Two Arbitrary Circular Holes Under Equal Biaxial Stresses. Journal of Engineering for Industry, Transactions of the ASME, November 1968.

REFERENCES (Continued)

8. Miyao, K.: Stresses in a Plate Containing a Circular Hole With a Notch. *Journal of the JSME*, Vol. 13, No. 58, 1970.
9. Nisida, M., and Shirota, Y.: Stress Concentration in a Plate due to Uniformly Spaced Circular Holes, *Proceedings of the Fourteenth Japan National Congress for Applied Mechanics*, 1965.
10. Davies, G. A. O.: Plate-Reinforced Holes. *The Aeronautical Quarterly*, February 1967.
11. Dhir, S. K.: Stresses Around Two Equal Reinforced Circular Openings in a Thin Plate. *International Journal of Solids and Structures*, Vol. 4, 1968.
12. Howard, I. C., and Morley, L. S. D.: The Stresses Around Holes in Plane Sheets. *The Aeronautical Quarterly*, November 1967.
13. Wittrick, W. H.: Analysis of Stress Concentration at Reinforced Holes in Infinite Sheets. *The Aeronautical Quarterly*, August 1960.
14. Hicks, R.: Asymmetrical Plate-Reinforced Circular Hole in a Uniformly End-Load Flat Plate. *The Aeronautical Quarterly*, May 1959.
15. Wittrick, W. H.: On the Axisymmetrical Stress Concentration at an Eccentrically Reinforced Circular Hole in a Plate. *The Aeronautical Quarterly*, February 1965.

REFERENCES (Concluded)

16. Hicks, R.: Variably Reinforced Circular Holes in Stressed Plates.
The Aeronautical Quarterly, August 1958.
17. Hicks, R.: Reinforced Elliptical Holes in Stressed Plates. Journal of
the Royal Aeronautical Society, October 1957.
18. Lo, C. C., and Leissa, A. W.: Bending of Plates With Circular Holes.
Acta Mechanica, Vol. 4, No. 1, 1967.
19. Bower, J. F.: Elastic Stresses Around Holes in Wide-Flange Beams.
Journal of the Structural Division, Proceedings of the American Society
of Civil Engineers, April 1966.
20. Bruhn, E. F.: Analysis and Design of Flight Vehicle Structures. Tri-
state Offset Company, Cincinnati, Ohio, 1965.